

SSP Pumps in the Chemical Industry

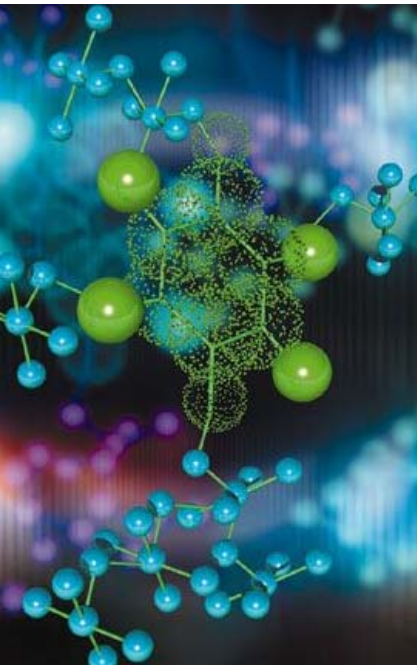

Inside View

This document has been produced to support pump users at all levels, providing an invaluable reference tool. It includes information on pumped media and guidelines as to the correct selection and successful application of SSP Rotary Lobe Pumps in the Chemical Industry.

Main sections are as follows:

1. Introduction
2. General Applications Guide
3. Pump Materials of Construction
4. Compliance with International Standards and Directives
5. Pumped Media
6. Pump Selection and Application Summary

The information provided in this document is given in good faith, but Alfa Laval Ltd, SSP Pumps is not able to accept any responsibility for the accuracy of its content, or any consequences that may arise from the use of the information supplied or materials described.

Contents

	Page
Section 1.0 Introduction	3
Introduction of SSP Pumps in the Chemical Industry	
Section 2.0 General Applications Guide	5
Overview of the pump ranges currently available from SSP Pumps and which particular pumps to apply within various application areas	
Section 3.0 Pump Materials of Construction	9
Description of the materials, both metallic and elastomeric, used in the construction of SSP Pump ranges	
3.1 Standard Pump Materials of Construction	10
3.2 Special Materials	11
3.3 Elastomers	14
Section 4.0 Compliance with International Standards and Directives	17
Description of the international standards and directives applicable to SSP Pump ranges	
4.1 ATEX Directive	17
4.2 EHEDG	18
4.3 FDA	18
4.4 EN10204 3.1	19
4.5 EN10204 2.2	19
Section 5.0 Pumped Media	21
Description of various groups of pumped media generally found within the Chemical Industry. Also general points for careful consideration during the selling / pump selection process.	
5.1 Acids	21
5.2 Adhesives	24
5.3 Detergents	27
5.4 Horticultural Products	29
5.5 Paints	30
5.6 Petrochemicals	31
5.7 Photographic Solutions	36
5.8 Plastics (or Resins)	38
5.9 Printing Inks	45
5.10 Solvents	47
Section 6.0 Pump Selection and Application Summary	49
Pump selection guidelines summary for the different pumped media found in the Chemical Industry	

1.0 Introduction

As a recognised market leader in pumping technology SSP Pumps has been at the forefront of supplying rotary lobe pumps to the chemical industry for over 50 years. Handling from low to high viscosity pumped media, the pumps smooth reliable low shear pumping action gentle handling of shear sensitive media and provide long trouble-free service. The SSP Pumps portfolio fulfils many fluid transfer requirements, with both stainless steel models for anti-corrosive and hygienic applications and ductile iron models for less aggressive chemical uses.



2.0 General Applications Guide

This section gives an overview of the pump ranges currently available from SSP Pumps and which particular pumps to apply within various application areas in the Chemical Industry.

Within the various chemical industry processes many opportunities exist for utilising SSP rotary lobe pumps, not only for the final product but other processes such as by-products, sampling and waste.

Walk the Process

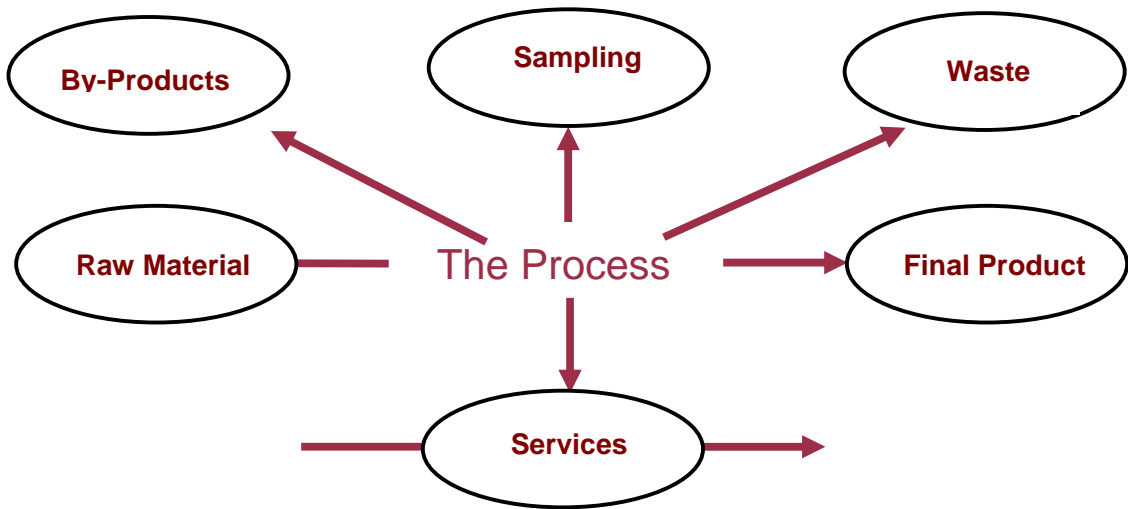

Opportunities

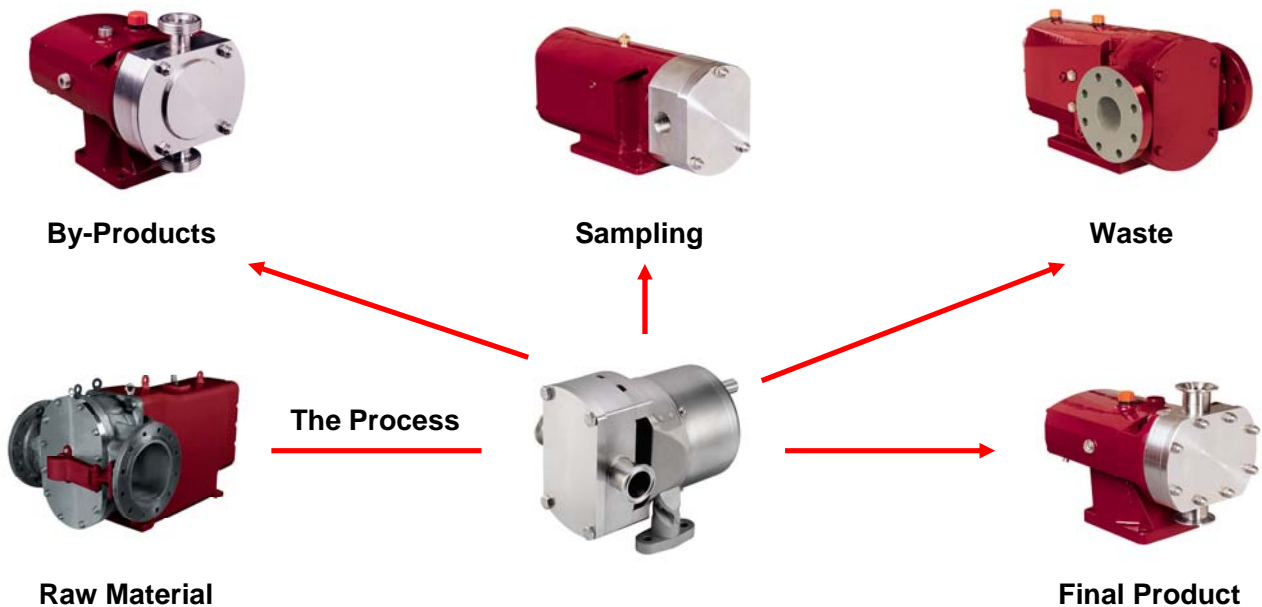

Within the chemical industry typical application areas are:

- General Transfer
- Tanker Loading and Unloading
- Dosing
- Filling
- Bulk Storage

Typical pumped media groups are as follows:

- Acids
- Adhesives
- Detergents
- Horticultural Products
- Paints
- Petrochemicals
- Photographic Solutions
- Plastics (or Resins)
- Printing Inks
- Solvents

Pump Series Generally To Be Found

Media Handled	Pump Series							
	S	X	L	A	G	D	N	M
Acids	✓	-	-	✓	-	-	-	-
Adhesives	✓	-	✓	✓	-	-	-	-
Detergents	✓	✓	✓	✓	-	-	-	-
Horticultural Products	✓	-	✓	-	-	-	✓	-
Paints	✓	-	✓	✓	✓	✓	-	-
Petrochemicals	✓	-	✓	-	✓	✓	✓	✓
Photographic Solutions	✓	✓	-	-	-	-	✓	✓
Plastics (or Resins)	✓	-	✓	-	-	✓	-	-
Printing Inks	✓	-	-	✓	✓	✓	-	✓
Solvents	✓	✓	✓	-	-	✓	✓	✓

General Applications Guide

The table shown below gives a general guide as to the SSP pump series required to suit the application

General Requirements	Pump Series							
	S	X	L	A	G	D	N	M
Pumped Media								
Max. Viscosity - cP	1000000	1000000	1000000	1000000	1000000	1000000	10000	10000
Max. Pumping Temperature	200°C (392°F)	150°C (302°F)	130°C (266°F)	200°C (392°F)	200°C (392°F)	200°C (392°F)	100°C (212°F)	100°C (212°F)
Min. Pumping Temperature	-20°C (-4°F)	-20°C (-4°F)	-20°C (-4°F)	-20°C (-4°F)	-20°C (-4°F)	-20°C (-4°F)	-20°C (-4°F)	-20°C (-4°F)
Ability to pump abrasive products	No	No	No	No	Yes	Yes	No	No
Ability to pump fluids containing air or gases	Yes	Yes	Yes	Yes	Yes	Yes	No	No
Ability to pump solids in suspension	Yes	Yes	Yes	Yes	Yes	Yes	No	No
CIP capability	Yes	Yes	Yes	Yes	No	No	No	No
Dry running capability (when fitted with flushed mechanical seals)	Yes	Yes	Yes	Yes	Yes	Yes	No	No
Self draining capability	Yes	Yes	Yes	No	No	No	No	No
Performance								
Max. Capacity - m ³ /h	106	115	48	680	680	180	2.3	1.5
Max. Capacity - US gall/min	466	506	211	2992	2992	792	10	7
Max. Discharge Pressure - bar	20	15	8	10	10	15	7	7
Max. Discharge Pressure - psig	290	215	115	145	145	215	100	100
Compliance with International Standards and Directives								
ATEX	Yes	Yes	No	No	No	Yes	No	No
EHEDG	Yes	Yes	Yes	No	No	No	No	No
EN10204 2.2	Yes	Yes	Yes	Yes	Yes	Yes	Yes	Yes
EN10204 3.1	Yes	Yes	No	No	No	No	No	No
FDA	Yes	Yes	Yes	No	No	No	No	No

3.0 Pump Materials of Construction

This section describes the materials, both metallic and elastomeric, used in the construction of SSP Pump ranges within the Chemical Industry.

Pumps today can be manufactured from a different number of materials dependent upon the product being pumped and its environment. For SSP rotary lobe pumps this is generally stainless steel and ductile iron and can be split into two main categories:

- Product Wetted Parts
(i.e. Metallic and elastomeric parts in contact with the pumped media)

This would normally comprise of the following main components:

- Rotors
- Rotorcase
- Rotorcase Cover
- Shafts
- Rotor Retention Device
- Product Shaft Seals

- Non-product Wetted Parts
(i.e. Metallic and elastomeric parts not in contact with the pumped media)

This would normally comprise of the following main components:

- Gearcase
- Gearcase Cover

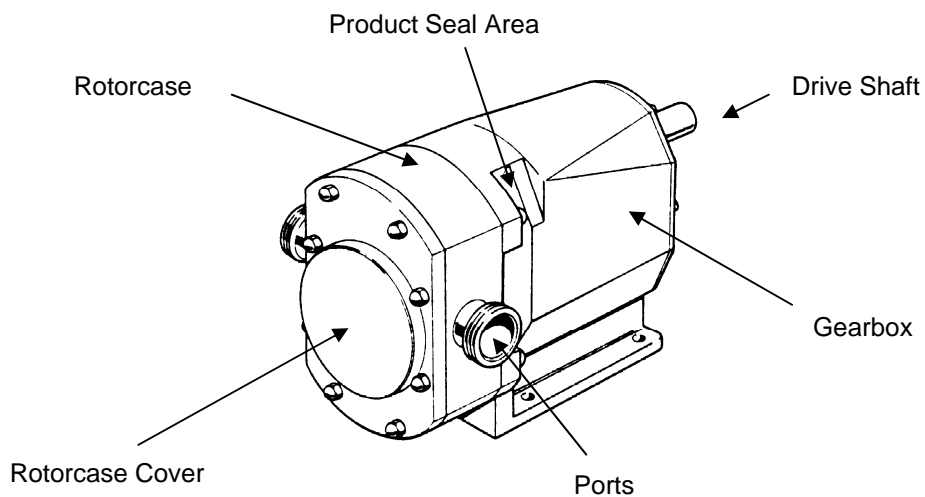

3.1 Standard Pump Materials of Construction

Pump Series	Main Pump Component				
	Gearcase	Rotor	Rotorcase	Rotorcase Cover	Shaft
S	Cast iron	316L stainless steel, Non-galling alloy or rubber covered	316L stainless steel	316L stainless steel	316L or duplex stainless steel (for higher pressures)
X	Cast iron	316L stainless steel	316L stainless steel	316L stainless steel	Duplex stainless steel
L	304 stainless steel canister and electroless nickel plated bearing housing	316L stainless steel	316L stainless steel	316L stainless steel	Duplex stainless steel
A	Cast iron	316 type stainless steel	316 type stainless steel	316 type stainless steel	316 type stainless steel or S143 (for higher pressures)
G	Cast iron	Ductile iron or urethane covered	Ductile iron	Hardened mild steel	Medium or high strength carbon steel (for higher pressures)
D	Cast iron	Ductile iron, rubber or urethane covered	Ductile iron	Hardened mild steel	Surface hardened carbon steel
N	Cast iron	316 type stainless steel	316 type stainless steel	316 type stainless steel	316 type stainless steel
M	Non-applicable	316 type stainless steel	316 type stainless steel	316 type stainless steel	316 type stainless steel

3.2 Special Materials

For those particularly aggressive applications that demand pumps to be manufactured in materials other than 316L and duplex stainless steel, SSP Pumps are able to supply product wetted parts in Uranus B6 (904L) and nickel alloys such as HASTELLOY® and others.

With regards to corrosion, the nickel alloys lie between the stainless steels and the exotic materials, such as tantalum. They are commonly used in aggressive inorganic acids and chloride-bearing environments, where many of the stainless steels are prone to stress-corrosion cracking, pitting, and crevice attack. Within the same performance band as the corrosion-resistant nickel alloys lie zirconium and titanium alloys.

Corrosion-Resistant Alloys Hierarchy

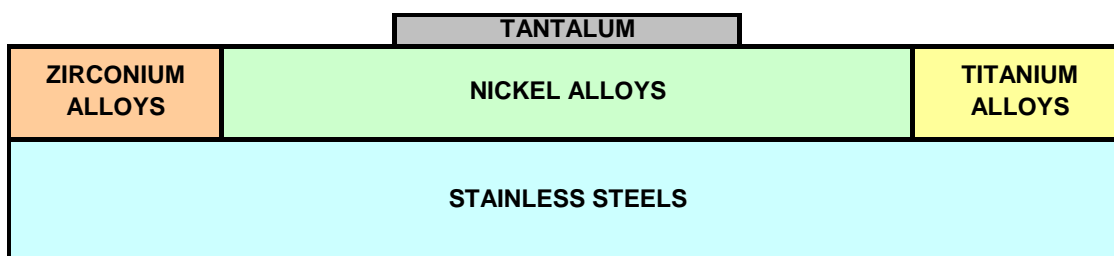

There are six, main nickel alloy groups:

- Ni (pure nickel)
 - for caustic service
- Ni-Cu (nickel-copper) and Ni-Mo (nickel-molybdenum)
 - for reducing acids
- Ni-Fe-Cr (nickel-iron-chromium)
 - for oxidising acids
- Ni-Cr-Si (nickel-chromium-silicon)
 - for super oxidising acids, such as concentrated sulphuric
- Ni-Cr-Mo (nickel-chromium-molybdenum)
 - the group which contains the most versatile alloys

With regard to the HASTELLOY® alloys, the B-types fall within the Ni-Mo group, the C-types fall within the Ni-Cr-Mo group, the D-types fall within the Ni-Cr-Si group and the G-types fall within the Ni-Fe-Cr group.

HASTELLOY® C-22 and C276 Alloys

These are generally considered to be versatile corrosion-resistant alloys, having excellent resistance to a wide variety of chemical process environments including strong oxidisers such as ferric and cupric chlorides, hot contaminated media (organic and inorganic), chlorine, formic and acetic acids, acetic anhydride, seawater and brine solutions. It is also one of the few materials able to withstand the corrosive effects of wet chlorine gas, hypochlorite and chlorine dioxide. As these alloys are so versatile they can be used where 'upset' conditions are likely to occur or in multi-purpose plants. C-22 and C276 alloys also have excellent resistance to pitting, and to stress-corrosion cracking.

HASTELLOY® B-2 and B-3 Alloys

These have excellent resistance to hydrochloric acid at all concentrations and temperatures, and also withstand hydrogen chloride, sulphuric, acetic and phosphoric acids. These alloys have excellent resistance to pitting, stress-corrosion cracking, knife-line and heat-affected zone attack.

However, B-2 and B-3 alloys are not recommended in the presence of ferric or cupric salts as these salts may cause rapid corrosion failure. Ferric or cupric salts may develop when hydrochloric acid comes in contact with iron or copper. Therefore, when HASTELLOY® B-2 and B-3 alloys are used in conjunction with iron or copper piping in a system containing hydrochloric acid, the presence of these salts could cause B-2 and B-3 alloys to fail prematurely.

Uranus B6

Uranus B6, otherwise known as 904L, is a low carbon high alloy austenitic stainless steel. The addition of copper to this grade gives it greatly improved resistance to strong reducing acids, such as sulphuric acid, particularly in the very aggressive 'mid concentration' range. Although originally developed for its resistance to sulphuric acid it also has a very high resistance to a wide range of environments such as warm seawater and other high chloride areas. It is also highly resistant to pitting, crevice and stress corrosion cracking from chloride attack.

Typical application areas are Processing plants for sulphuric, phosphoric and acetic acids, Pulp and paper processing, Components in gas scrubbing plants, Seawater cooling equipment, and Oil refinery components.

Titanium Alloys

Titanium was first used in chemical plants in the mid-1960's and its outstanding resistance to corrosion in oxidizing chloride environments, seawater and other aggressive media were rapidly established. The good corrosion resistance experienced in many environments is based on titanium's ability to form a stable oxide protective layer. Chemical applications areas include:

- Chlorine and chlorine compounds such as
 - a) Moist chlorine gas
 - b) Water solutions of chlorites, hypochlorites, perchlorates and chlorine dioxide
 - c) Chlorinated hydrocarbons
- Oxidizing mineral acids such as nitric, chromic, perchloric and hypochlorous
- Inorganic salt solutions such as
 - a) Chlorides of such minerals as sodium, potassium, magnesium, calcium, copper, manganese and nickel
 - b) Bromide salts
 - c) Sulfides, sulfates, carbonates, nitrates, chlorates, hypochlorites
- Organic acids such as acetic, terephthalic, formic, stearic and tannic
- Organic chemicals such as alcohols, aldehydes, esters, ketones and hydrocarbons
- Alkaline media such as sodium hydroxide, potassium hydroxide, calcium hydroxide, magnesium hydroxide and ammonium hydroxide

Zirconium Alloys

Like titanium, zirconium is a somewhat lesser known material. Zirconium alloys has excellent resistance to many strong acids, including nitric, hydrochloric and 70% concentrated sulphuric acid, as well as most organic acids. It also resists most chloride salt solutions and will withstand alkaline environments.

However, the material is vulnerable to attack by hydrofluoric acid, acidic oxidizing chloride solutions such as ferric or cupric chloride solutions, and wet chlorine environments.

Like titanium, zirconium forms a protective oxide layer in many corrosive applications. This layer is

'self-healing' in the presence of air or water, and protects the material's surface from chemical and mechanical attack.

3.3 Elastomers

SSP pump series incorporate elastomers of different material and characteristics dependent upon application within the pump and the media being pumped. Various elastomer types are specified below. It is difficult to predict the lifetime of elastomers as they will be affected by many factors, e.g. chemical attack, temperature, mechanical wear etc. The temperature range limitations given below are dependent upon the media being pumped. To verify satisfactory operation at these limits please consult our Technical Support.

NBR (Nitrile)

- Available as O-rings or Quad-rings (depending on pump type).
- Used as static or dynamic seals.
- Resistant to most hydrocarbons, e.g. oil and grease.
- Sufficiently resistant to diluted lye and diluted nitric acid.
- Temperature range - minus 40°C min to 100°C max. (*minus 40°F to 212°F max.*).
- Is attacked by ozone.

EPDM (Ethylene Propylene)

- Available as O-rings or Quad-rings (depending on pump type).
- Used as static or dynamic seals.
- Resistant to ozone and radiation.
- Temperature range - minus 40°C min to 150°C max. (*minus 40°F to 302°F max.*).
- Not resistant to organic and non-organic oils.

FPM (Fluorinated rubber)

- alternatively known as Viton.

- Available as O-rings or Quad-rings (depending on pump type).
- Used as static or dynamic seals.
- Often used when other rubber qualities are unsuitable.
- Resistant to most chemicals and ozone.
- Temperature range - minus 20°C min to 200°C max. (*minus 4°F to 392°F max.*).
- Not suitable for fluids such as water, steam, lye, acid and alcohol's being pumped hot.

PTFE (Polytetrafluoro Ethylene)

- Can be used as "cover" for O-ring seals of EPDM (i.e. encapsulated).
- Used as static or dynamic seals.
- Resistant to ozone.
- Resistant to almost all products.
- Temperature range - minus 30°C min to 200°C max. (*minus 22°F to 392°F max.*).
- Not elastic, tendency to compression set.

MVQ (Silicone)

- Used as static or dynamic seals.
- Resistant to ozone, alcohols and glycols.
- Temperature range - minus 50°C min to 230°C max. (*minus 58°F to 446°F max.*).
- Not resistant to steam, inorganic acids, mineral oils, or most organic solvents.

FEP (Fluorinated Ethylene Propylene)

- FEP covered (vulcanised) FPM or MVQ O-rings.
- Used as static or dynamic seals.
- Resistant to ozone.
- Resistant to almost all products.
- Suitable for temperatures up to approx. 200°C (392°F).
- More elastic than PTFE covered EPDM.

Kalrez® (Perfluoroelastomer)

- Used as static or dynamic seals.
- Resistant to ozone.
- Resistant to almost all products.
- Temperature range – minus 20°C min to 250°C max. (*minus 4°F to 482°F max.*).
- Elastic.

Chemraz® (Perfluoroelastomer)

- Used as static or dynamic seals.
- Resistant to ozone.
- Resistant to almost all products.
- Temperature range – minus 30°C min to 250°C max. (*minus 22°F to 482°F max.*).
- Elastic.

4.0 Compliance with International Standards and Directives

This section describes some of the international standards and directives applicable to SSP Pumps within the Chemical Industry.

These are primarily:

- ATEX Directive 94/9/EC
- EHEDG Cleanability and Installation Guidelines
- FDA Material Requirements
- EN 10204 3.1 Certified Material Traceability
- EN 10204 2.2 Certificate of Conformity

4.1 ATEX Directive

The ATEX Directive 94/9/EC covers equipment and protective systems that will be used in areas endangered by potentially explosive atmospheres created by the presence of flammable gases, vapours and dusts. Compliance with this directive introduced from 1st July 2003 is mandatory within the European Union (EU). Under this directive the equipment intended for use in potentially explosive atmospheres is divided into groups and categories which relate to the degree of protection as shown in the table below:

Equipment-groups (Annex I of the EC-Directive 94/9/EC)							
Group I (mines, mine gas and dust)		Group II (other explosive atmospheres gas/dust)					
Category M		Category 1		Category 2		Category 3	
1	2	G (gas) (Zone 0)	D (dust) (Zone 20)	G (gas) (Zone 1)	D (dust) (Zone 21)	G (gas) (Zone 2)	D (dust) (Zone 22)
for equipment providing a very high level of protection when endangered by an explosive atmosphere	for equipment providing a high level of protection when likely to be endangered by an explosive atmosphere	for equipment providing a very high level of protection when used in areas where an explosive atmosphere is very likely to occur		for equipment providing a high level of protection when used in areas where an explosive atmosphere is likely to occur		for equipment providing a normal level of protection when used in areas where an explosive atmosphere is less likely to occur	



SSP Series S, X and D rotary lobe pumps can be ATEX certified where generally classified for use in potentially explosive atmospheres under ATEX Directive 94/9/EC Group II, Categories 2 and 3. Should pumps be required for other groups or categories, please consult our Technical Support for further advice.

It is the responsibility of the end user to classify the group and the corresponding zone (dust or gas) in accordance with the EC Directive 1992/92/EC.

4.2 EHEDG



The European Hygienic Equipment Design Group (EHEDG) was formed primarily to promote hygiene during the processing and packaging of food products. Although this is a 'sanitary' standard there are certain applications at the 'high end' of the chemicals industry that demand this standard for cleanability, particularly photographic solutions where any cross-contamination of different batches would be very costly.

EHEDG objectives are to produce hygienic design guidelines that can be verified by standard test procedures. This requires a range of test procedures for a variety of equipment parameters including cleanability, pasteurisability, sterilisability and aseptic capability.

SSP Series S, X and L rotary lobe pumps meet EHEDG cleanability and comply with EHEDG installation guidelines.

4.3 FDA

The Food and Drug Administration (FDA) in the USA is the enforcement agency of the United States Government for food, drug and cosmetics manufacturing. It is responsible for new material approvals, plant inspections and material recalls. In the USA, the 'Food, Drug and Cosmetic Act' requires food, drug and cosmetic manufacturers to prove that their products are safe. The FDA's primary purpose is to protect the public by enforcing this Act.

The FDA can:

- approve plants for manufacturing.
- inspect plants at random.
- write general guidelines for good manufacturing processes.
- write specific criteria for materials in product contact.
- have certain expectations regarding design practices.

The FDA cannot:

- approve equipment outside of a particular use within a specific system.
- approve materials for use in pharmaceutical systems.
- write specific engineering or design requirements for systems.

For SSP Series S, X and L rotary lobe pumps the product wetted parts can be made available with FDA compliance.

4.4 EN 10204 3.1

With the increase in demand of hygiene within new food, chemical and pharmaceutical plants being built, material traceability of equipment supplied is increasingly important. The EN 10204 standard defines the different types of inspection documents required for metallic products. In particular, 3.1 of this standard refers to inspection documents being prepared at each stage of manufacture and supervised tests performed by authorised personnel independent of the manufacturer.

Both SSP Series S and X pumps can be supplied with material traceability to EN 10204 3.1 for the **stainless steel product wetted parts only**, defined as follows:

Series S - Rotorcase, rotors, rotor nuts, rotorcase cover, shafts and mechanical seal carriers including metal seal faces if applicable (single seal and inboard seal of double seal only). In addition, valve piston, if pressure relief valve is fitted to pump.

Series X - Rotorcase, rotors, rotor retainers, rotorcase cover and mechanical seal carriers including metal seal faces if applicable (single seal and inboard seal of double seal only).

4.5 EN 10204 2.2

This standard defines documents supplied to the purchaser, in accordance with the order requirements, for the supply of metallic products such as pumps. This takes the form of a certificate of conformity and can be applied to all SSP rotary lobe pump ranges.

5.0 Pumped Media

This section describes various groups of pumped media generally found within the Chemical Industry.

5.1 Acids

Although many type of acids are compatible with pumps constructed in 316L stainless steel, the more corrosive acids require the use of special materials. It should also be noted that as the majority of acids are toxic and of a hazardous nature, special attention need to be made to the appropriate sealing devices, which will be dependent upon temperature and concentration.

Below is a brief description of some of the common acids found within the chemical industry.

Sulphuric Acid

Sulphuric acid is one of the most important industrial chemicals used in the manufacture of fertilizers, detergents, plastics, synthetic fibres and pigments, and also used as a catalyst in the petroleum industry.

It should be noted that the use of 316L stainless steel is only suitable for handling very low or very high concentrations at low temperatures i.e. 0 - 36% conc. at temperatures up to 80°C or 92.5 - 98% conc. at temperatures up to 50°C. Applications outside of these parameters require the use of nickel alloys, such as HASTELLOY® B or C. The table shown below indicates which nickel alloy groups can be used dependent upon concentration and temperature.

Temperature	Concentration	Nickel Alloy Group					
		Ni-Cu <i>Nickel-Copper</i>	Ni-Mo <i>Nickel-Molybdenum</i>	Ni-Fe-Cr <i>Nickel-Iron-Chromium</i>	Ni-Cr-Mo <i>Nickel-Chromium-Molybdenum</i>	Ni-Cr-Si <i>Nickel-Chromium-Silicon</i>	
Low < 52°C	Low < 30%	✓	✓	✓	✓	✓	
	Med 30 - 70%	✓	✓	✓	✓	✓	
	High > 70%	x	✓	✓	✓	✓	
Med 52 - 79°C	Low < 30%	✓	✓	✓	✓	✓	
	Med 30 - 70%	✓	✓	✓	✓	✓	
	High > 70%	x	✓	x	✓	x	
High > 79°C	Low < 30%	✓	✓	✓	✓	✓	
	Med 30 - 70%	x	✓	x	x	x	
	High > 70%	x	✓	x	x	x	

Hydrochloric Acid

Hydrochloric acid has many uses as a strong inorganic acid, for instance in the manufacture of chlorides, dissolution of minerals, pickling and etching of metals, acidification of brine in chlor-alkali electrolysis and neutralisation of alkaline product or waste materials.

It is extremely corrosive to most metals and alloys. Some nickel alloys have a good corrosion resistance to hydrochloric acid, although this is very much dependent concentration and temperature as shown in the table below:

Temperature	Concentration	Nickel Alloy Group				
		Ni-Cu <i>Nickel-Copper</i>	Ni-Mo <i>Nickel-Molybdenum</i>	Ni-Fe-Cr <i>Nickel-Iron-Chromium</i>	Ni-Cr-Mo <i>Nickel-Chromium-Molybdenum</i>	Ni-Cr-Si <i>Nickel-Chromium-Silicon</i>
Low < 52°C	Low < 5%	✓	✓	✓	✓	x
	Med 5 - 10%	x	✓	x	✓	x
	High 10 - 20%	x	✓	x	✓	x
Med 52 - 79°C	Low < 5%	x	✓	x	✓	x
	Med 5 - 10%	x	✓	x	x	x
	High 10 - 20%	x	✓	x	x	x
High > 79°C	Low < 5%	x	✓	x	x	x
	Med 5 - 10%	x	✓	x	x	x
	High 10 - 20%	x	✓	x	x	x

Hydrofluoric Acid

Hydrofluoric acid has become very important within the organic chemical and plastics industries. It is an extremely aggressive chemical, which readily attacks the reactive metal alloys. However, some nickel alloys do provide reasonable corrosion resistance to this acid as shown in the table below:

Temperature	Concentration	Nickel Alloy Group				
		Ni-Cu <i>Nickel-Copper</i>	Ni-Mo <i>Nickel-Molybdenum</i>	Ni-Fe-Cr <i>Nickel-Iron-Chromium</i>	Ni-Cr-Mo <i>Nickel-Chromium-Molybdenum</i>	Ni-Cr-Si <i>Nickel-Chromium-Silicon</i>
Low < 52°C	Low < 5%	✓	✓	✓	✓	x
	Med 5 - 20%	✓	✓	x	✓	x
	High 20 - 35%	✓	✓	x	✓	x
Med 52 - 79°C	Low < 5%	✓	✓	x	✓	x
	Med 5 - 20%	✓	✓	x	✓	x
	High 20 - 35%	x	x	x	x	x
High > 79°C	Low < 5%	x	x	x	x	x
	Med 5 - 20%	x	x	x	x	x
	High 20 - 35%	x	x	x	x	x

Phosphoric Acid

Phosphoric acid is used primarily in the manufacture of fertilizers, pharmaceuticals and detergents producing water softeners. Also in the steel industry, it is used to for cleaning and rust-proofing purposes.

Most phosphoric acid is however used in the production of fertilizers. Phosphorus is one of the elements essential for plant growth. Organic phosphates are the compounds, which provide the energy for most of the chemical reactions that occur in living cells. Therefore, enriching soils with phosphate fertilizers enhances plant growth.

Nitric Acid

Nitric acid is produced in large quantities from ammonia. The major consumption of nitric acid (75-85%) is in the manufacture of fertilizers for agriculture. Another use for nitric acid is in the production of explosives. The most important product is ammonium nitrate, which is used in both sectors (fertilizers and explosives).

Nitric is a strong oxidizing acid and in general terms, the stainless steels are more resistant than the chromium bearing nickel alloys. However, there are occasions when nickel alloys are preferred, for example in heat exchangers (*where the stainless steels might not possess sufficient pitting resistance on the cooling water side*), in multi-purpose chemical systems (*where a batch process involving nitric acid may be followed by another involving a different acid*), and in acid mixtures (*where other acids are corrosive to stainless steel*).

Acetic Acid

Acetic acid is mainly used in the manufacture of vinyl acetate leading to polyvinyl acetate and polyvinyl alcohols used for paints and plastics. Other uses are in the production of a range of acetates, for instance sodium acetate. Acetic acid can also be converted to acetic anhydride which is used to manufacture cellulose acetate, a synthetic textile.

Formic Acid

Formic acid is used in the manufacturing of fumigants, animal feed additives, and commercial paint strippers. The largest single use of formic acid is as a silage additive in Europe. Formic acid is also used in textile dyeing and finishing, leather tanning, nickel plating baths, electroplating, coagulating rubber latex, regenerating old rubber, and de-hairing and plumping hides. Other uses are to make metal salts, including nickel, cadmium, and potassium formates. It is also used as a solvent for perfumes, and in the manufacturing of lacquers, glass, and vinyl resin plasticisers.

Chromic Acid

Chromic acid is used in the preparation of wood preservatives and in the process of chrome plating.

General points for careful consideration during selling / pump selection process:

- *Compatibility with metallic and elastomeric pump components - are there any special material requirements?*
- *Media temperature and concentration with respect to compatibility?*
- *Vapour pressure with respect to Net Positive Suction Head required (NPSHr)?*
- *Pump speed (only viscosity dependent)*
- *Primary seal selection - hazardous nature of media?*

5.2 Adhesives

Adhesives are generally divided into two types; water-based and solvent-based.

Water-based adhesives comprise of materials or compounds that can be dissolved or dispersed in water. These adhesives generally develop a bond by losing water through evaporation or penetration into the substrates. At least one substrate must be absorbent or porous in order to form a strong bond. Water-based adhesives include resin-based adhesives such as vinyl acetate-ethylene, styrene butadiene rubbers and acrylics. The largest volume market for these adhesives is packaging adhesives used for paper and paperboard packaging, including boxes, folded cartons and paper bags. Emulsions also serve as binders for pressure sensitive adhesives used for tapes and labels, and in consumer products, such as household glue and carpenter's wood glue.

Types of industrial adhesives are hot melt adhesives, epoxy adhesives, polyurethane adhesives, sealants, thermoset adhesives, UV curing adhesives, silicon adhesives, acrylic adhesives and other related industrial adhesives. Industrial adhesives include a wide variety of organic and inorganic chemical compounds for joining components. This classification also includes industrial sealants, which are used to fill gaps between seams, or on surfaces, and to contain fluids, prevent leaks, and prevent infiltration of unwanted material. Industrial adhesives are generally classified based on their chemical compositions or their adhesion properties.

Industrial adhesives defined by their chemical compositions include:

- **Acrylic and acrylate adhesives**
These are known for their excellent environmental resistance and fast-setting times when compared to other resin systems.
- **Cyanoacrylate adhesives**
These are one-part acrylate adhesives that cure instantly on contact with mated surfaces through a reaction with surface moisture. Cyanoacrylates are often called super glues.
- **Epoxy adhesives**
These are chemical compounds for joining components.
- **Phenolic, melamine and formaldehyde resins**
These are thermosetting adhesives that offer strong bonds and good resistance to high temperatures.
- **Polyurethane adhesives**
These provide excellent flexibility, impact resistance and durability.
- **Rubber adhesives**
These and rubber sealants provide highly flexible bonds and are usually based on butadiene-styrene, butyl, polyisobutylene or nitrile compounds.
- **Silicone adhesives**
These and silicone sealants have a high degree of flexibility and very high temperature resistance.

Industrial adhesives defined by their adhesion properties include:

- **Hot melt adhesives**
These can be repeatably softened by heat and hardened or set by cooling, which allows parts to be removed or repositioned during assembly.
- **Pressure sensitive adhesives and contact adhesives**
These adhere to most surfaces with very slight pressure.
- **Thermoset adhesives**
These are crosslinked polymeric resins cured using heat, or heat and pressure.
- **UV curing adhesives (radiation and light curable)**
These use ultraviolet light or other radiation sources to initiate curing, which allows a permanent bond without heating.

SSP Pump Options

Heating Jackets / Saddles

To prevent the adhesives being cooled in the pump and thereby become viscous or allowed to solidify, consideration should be given in fitting the pumphead with a heating jacket to the rotorcase cover and/or saddles to the rotorcase. These should be in operation approximately 15 minutes prior to pump start up and remain in operation 15 minutes after pump shut down. The maximum pressure and temperature of the heating fluid is 3.5 bar (50 psi) and 150°C (302°F) respectively.

Series S pumps can be fitted with jackets to the rotorcase cover and/or saddles to the rotorcase. Series X and N pumps can only be fitted with jackets to the rotorcase cover.

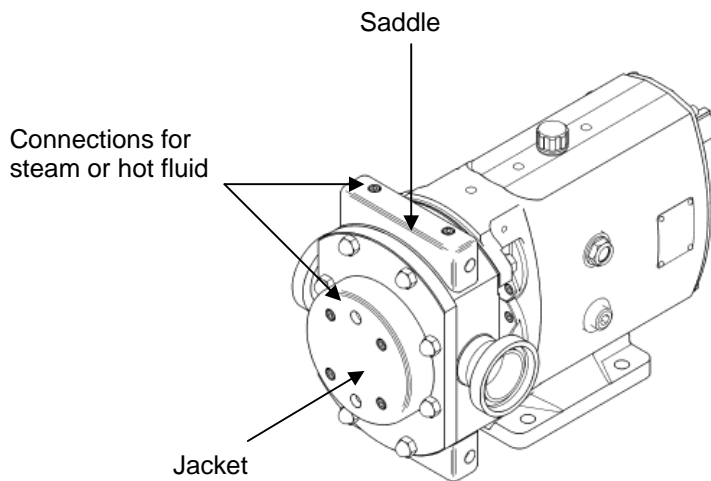

Rectangular Inlet / Rectangular to Round Adaptors

For handling extremely viscous products and/or large solids that would naturally bridge a smaller port, SSP Series S rotary lobe pumps can be supplied with a rectangular inlet. Usually the pump will be in vertical port orientation to allow the pumped media to flow into the pumping chamber under gravity from a hopper mounted directly above or mounted with an adaptor to facilitate connection to large diameter pipework.

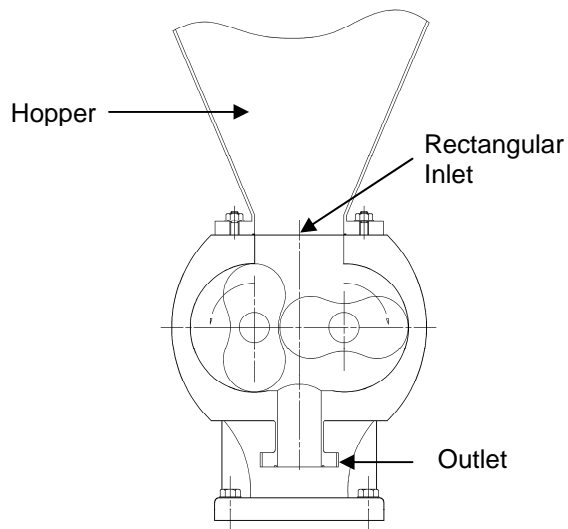

Typical Rectangular to Round Adaptor



General points for careful consideration during selling / pump selection process:

- *Compatibility with elastomeric pump components?*
- *Media viscosity may be very high - consider porting arrangement and any pressurised pump inlet?*
- *Dilatency of media - viscosity may increase as shear rate increases?*
- *Media thermosetting?*
- *Primary seal selection - hazardous and solidifying nature of media?*
- *Heating pumphead to prevent media from solidifying?*
- *Avoid fitting integral pressure relief valve due to high viscosity?*
- *Consider use of soft start electronic devices?*

5.3 Detergents

A detergent is a chemical compound that cleans. In the sense that a soap cleans things, it can be considered a detergent. However, chemists generally make a distinction between soaps and detergents, since soaps are salts of carboxylic acids, and detergents are sulphate or sulphonate salts.

The basic constituent of detergents, both liquid and powder form, fabric conditioners, washing up liquid and all related products, are surfactants i.e. surface acting agents. Detergents (and other surfactants) increase the spreading and wetting ability of water by reducing its surface tension. In order to perform as detergents, they must have certain chemical structures: their molecules must contain a hydrophobic (water-insoluble) part, such as fatty acid or a rather long chain carbon group, such as fatty alcohol's or alkylbenzene. The molecule must also contain a hydrophilic (water-soluble) group, such as in fatty alcohol sulphate or alkylbenzene sulphonate, or a long ethylene oxide chain in non-ionic synthetic detergents. This hydrophilic part makes the molecule soluble in water. In general, the hydrophobic part of the molecule attaches itself to the solid or fibre and onto the soil, and the hydrophilic part attaches itself to the water.

Surfactants are classified by their ionic (electrical charge) properties in water:

- Anionic (negative charge)
- Non-ionic (no charge)
- Cationic (positive charge)
- Amphoteric (either positive or negative charge)

- **Anionic Detergents**

The anionic detergents are used extensively in most detergent systems, such as dishwash liquids, laundry liquid detergents, laundry powdered detergents, car wash detergents, shampoo's etc.

The common anionic detergents can be placed into the following main groups:

a) Alkyl Aryl Sulphonates

Linear alkyl benzene sulphonate would be the highest quantity used of any detergent in the world, and the alkyl aryl sulphonates as a group would represent more than 40% of all detergent used. They are cheap to manufacture, very efficient, and the petroleum industry is a starting point for the base raw material. The most important alkyl aryl condensate is DDB (dodecyl benzene). DDB is sulphonated to DDBSA (dodecyl benzene sulphonic acid), and this in turn is used as a detergent base, where it is neutralised with a base, such as sodium hydroxide, monoethanolamine, triethanolamine, potassium hydroxide, etc.

b) Long Chain (Fatty) Alcohol Sulphates

Made from fatty alcohol's, and sulphated, these are used extensively in laundry detergents. They can be produced with varying carbon chain lengths.

c) Others

These are the olefine sulphates and sulphonates, alpha olefine sulphates and sulphonates, sulphated monoglycerides, sulphated ethers, sulphosuccinates, alkane sulphonates, phosphate esters, alkyl isethionates, and sucrose esters.

- **Cationic Detergents**

These have poor detergency, and are used more for germicides, fabric softeners, and specialist emulsifiers. You cannot mix cationic and anionic detergents together, as it causes precipitation. The cationic detergents invariably contain amino compounds. The most widely used would be the quaternary ammonium salts, such as cetyl trimethylammonium chloride, a well known germicide.

- **Non-ionic Detergents**

The vast majority of all non-ionic detergents are condensation products or ethylene oxide with a hydrophobe. This group of detergents is the single biggest group of all detergents.

- **Amphoteric Detergents**

These have the characteristics of both anionic detergents and cationic fabric softeners. They tend to work best at neutral pH, and are found in shampoo's, skin cleaners and carpet shampoo.

Series S5 pump handling detergent in Finland

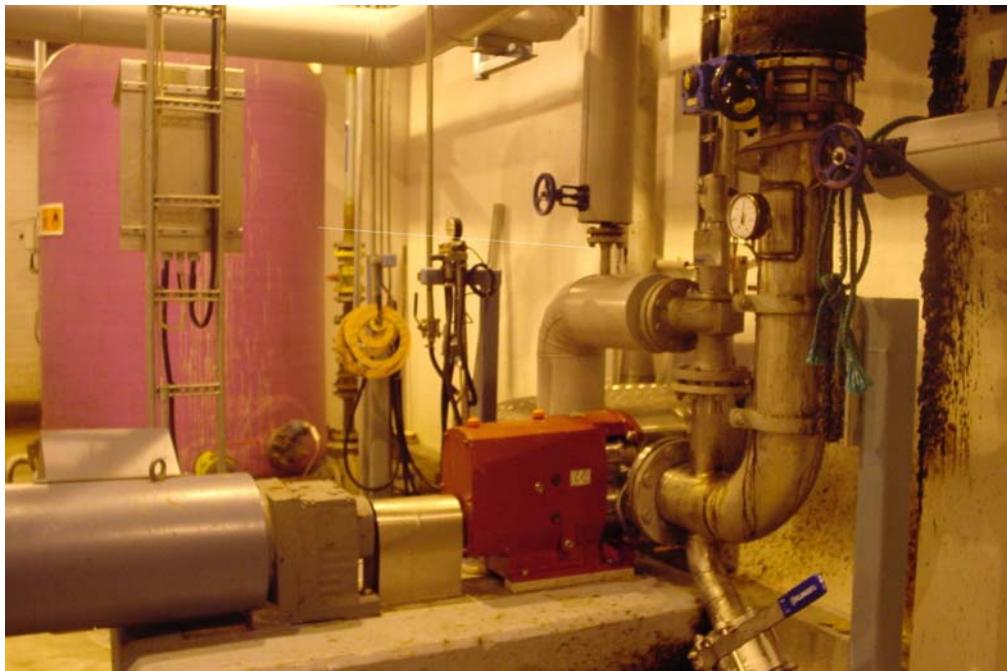

General points for careful consideration during selling / pump selection process:

- *Compatibility with metallic and elastomeric pump components - are there any special material requirements?*
- *Temperature sensitive?*
- *Mineral solids present?*
- *Vapour pressure with respect to Net Positive Suction Head required (NPSHr)?*
- *Pump shaft speed - keep relatively low to avoid possible foaming and excessive wear?*
- *Primary seal selection - flushed seals with steam?*

5.4 Horticultural Products

Horticulture is the name given to the science of growing fruit, flowers and vegetables. Within this application area, two types of pumped media are of interest to SSP as follows:

Fertilizers

Fertilizers are chemicals given to plants with the intention of promoting growth and are usually applied either via the soil or by foliar spraying.

Fertilizers typically provide, in varying proportions the three major nutrients (nitrogen, potassium and phosphorus), the secondary plant nutrients (calcium, sulphur, magnesium), and sometimes trace elements (or micronutrients) with a role in plant nutrition i.e. boron, manganese, iron, zinc, copper and molybdenum.

Weedkillers

Weedkillers are chemicals that kill some or all plants. Selective herbicides are effective with cereal crops because they kill all broad-leaved plants without affecting grasslike leaves. Those that kill plants include sodium chlorate and paraquat. The widespread use of weedkillers in agriculture has led to an increase in crop yield but also to pollution of soil and water supplies and killing of birds and small animals, as well as creating a health hazard for humans.

General points for careful consideration during selling / pump selection process:

- *Compatibility with metallic and elastomeric pump components - are there any special material requirements?*
- *Pump shaft speed - keep relatively low to avoid damage to any crystalline structures and excessive wear due to any abrasive solids present?*
- *Primary seal selection - hazardous nature of media?*

5.5 Paints

Paint is a pigmented liquid or powder that is used to protect and/or improve the look of substrates. Paints are generally divided into two types: water-base and oil-base. All types of paint are compatible with pumps constructed in 316L stainless steel. Also in certain instances ductile iron is compatible with oil-base paints and therefore Series D and G pumps could be considered.

Paints consist of three basic components that greatly influence its quality and use which are Pigments, Binders and Solvents.

- **Pigments** typically are made up of minutely sized particles of titanium dioxide or clay, which can remain suspended in a liquid base for upon mixing over extended periods of time. The pigment usually, considered as the color component of the paint also gives the paint its coverage properties and its ability to provide ultra violet protection.
- **Binders** or liquid resin is used for adhesion, which holds everything in the paint (including the pigments) together giving the paint its ability to bond, and endure the elements. Linseed oil, tung oil or alkyd resins are the primary binders for oil-base paints and 100% acrylic or vinyl acrylic are the binders for water-base paint.
- **Solvents** are used to act as a 'carrier' for the pigments and binders to provide the proper consistency for the paint. In oil-base paints the solvent is mineral spirits and in water or latex base paints, water is the solvent.

General points for careful consideration during selling / pump selection process:

- *Compatibility with metallic and elastomeric pump components?*
- *Temperature sensitive?*
- *Abrasive solids present?*
- *High viscosity?*
- *Pump shaft speed - keep relatively low to avoid high shear rates and excessive wear?*
- *Primary seal selection - hazardous and solidifying nature of media?*

5.6 Petrochemicals

Petrochemicals are chemicals manufactured from petroleum (crude oil) and natural gas. Petroleum and natural gas consist of hydrocarbon molecules, which are comprised of one or more atoms, to which hydrogen atoms are attached.

Crude Oil

Crude oil is the term for 'unprocessed' oil, and is typically extracted from an onshore or offshore reservoir by means of inherent pressure or pumps and also extracted from oil sands. Crude oil is a fossil fuel, meaning that it was made naturally from decaying plants and animals living in ancient seas millions of years ago - anywhere you find crude oil, it was once a sea bed. Crude oils vary in colour, from clear to tar-black, and in viscosity, from water to almost solid.

Crude oils contain hydrocarbons, which are molecules that contain hydrogen and carbon and come in various lengths and structures, from straight chains to branching chains to rings. Hydrocarbons can take on many different forms. The smallest hydrocarbon is methane (CH₄), which is a gas lighter than air. Longer chains with 5 or more carbons are liquids and very long chains are solids like wax or tar. Hydrocarbon chains are extremely versatile and chemically cross-linking hydrocarbon chains can produce products such as synthetic rubber, nylon and plastics.

The major classes of hydrocarbons in crude oils include:

- **Paraffins**
These can be gasses or liquids at room temperature depending upon the molecule. Typical examples are methane, ethane, propane, butane, isobutane, pentane, and hexane.
- **Aromatics**
These are typically liquids such as benzene and naphthalene
- **Napthenes or Cycloalkanes**
These are typically liquids at room temperature such as cyclohexane and methyl cyclopentane.

Other hydrocarbons include:

- **Alkenes**
These can be liquid or gas. Typical examples are ethylene, butene and isobutene.
- **Dienes and Alkynes**
These can be liquid or gas. Typical examples are acetylene and butadienes.

In refining crude oil, the hydrocarbons are required to be separated by distillation. Different hydrocarbon chain lengths all have progressively higher boiling points. Crude oil is heated and their vaporisation temperatures pull out the different chains. Each different chain length has a different property that provides various derivatives and uses as follows:

- **Petroleum gas** - used for heating, cooking, making plastics
 - Small alkanes (1 to 4 carbon atoms).
 - Commonly known by the names methane, ethane, propane, and butane.
 - Boiling range = less than 40°C (104°F).
 - Often liquefied under pressure to create LPG (liquefied petroleum gas).
- **Naphtha or Ligroin** - intermediate that will be further processed to make gasoline.
 - Mix of 5 to 9 carbon atom alkanes
 - Boiling range = 60 - 100°C (140 - 212°F).
- **Gasoline** - motor fuel
 - Liquid
 - Mix of alkanes and cycloalkanes (5 to 12 carbon atoms)
 - Boiling range = 40 - 205°C (104 - 401°F).
- **Kerosene** - fuel for jet engines and tractors; starting material for making other products.
 - Liquid
 - Mix of alkanes (10 to 18 carbon atoms) and aromatics
 - Boiling range = 175 - 325°C (350 - 617°F).
- **Gas oil or Diesel distillate** - used for diesel fuel and heating oil, starting material for making other products.
 - Liquid
 - Alkanes containing 12 or more carbon atoms
 - Boiling range = 250 - 350°C (482 - 662°F).
- **Lubricating Oil** - used for motor oil, grease, and other lubricants.
 - Liquid
 - Long chain (20 to 50 carbon atoms) alkanes, cycloalkanes, and aromatics
 - Boiling range = 300 - 370°C (572 - 700°F).
- **Heavy gas or Fuel Oil** - used for industrial fuel; starting material for making other products.
 - Liquid
 - Long chain (20 to 70 carbon atoms) alkanes, cycloalkanes, and aromatics
 - Boiling range = 370 - 600°C (700 - 1112°F).
- **Residuals** - coke, asphalt, tar, waxes, starting material for making other products.
 - Solid
 - Multiple-ringed compounds with 70 or more carbon atoms.
 - Boiling range = greater than 600°C (1112°F).

In the refining process the oil is separated into various useful substances components, known as fractions. This process is called fractional distillation, whereby the crude oil is heated up and allowed to vaporise. This vapour is subsequently condensed. Newer techniques use chemical processing on some of the fractions to make others in a process called conversion. Chemical processing, for example, can break longer chains into shorter ones. This allows a refinery to turn diesel fuel into gasoline depending on the demand for gasoline.

Refineries must treat the fractions to remove impurities and combine the various fractions (processed, unprocessed) into mixtures to make desired products. For example, different mixtures of chains can create gasolines with different octane ratings.

In chemical processing, one fraction can be changed into another by one of three methods:

- Cracking - breaking large hydrocarbons into smaller pieces
- Unification - combining smaller pieces to make larger ones
- Alteration - rearranging various pieces to make desired hydrocarbons

Distilled and chemically processed fractions are treated to remove impurities, such as organic compounds containing sulfur, nitrogen, oxygen, water, dissolved metals and inorganic salts. After the fractions have been treated, they are cooled and then blended together to make various products such as:

- Gasoline of various grades with or without additives
- Lubricating oils to various weights and grades (e.g. 10W-40, 5W-30).
- Kerosene of various grades
- Jet fuel
- Diesel fuel
- Heating oil
- Chemicals of various grades for making plastics and other polymers

Typical petrochemical media handled by SSP rotary lobe pumps are crude, slop and lubricating oils, jet fuel, diesel fuel and various chemicals. In general terms, pumps constructed in 316L stainless steel will be compatible for all types of oil. However, the Series D and G ductile iron pumps should be considered for crude oil dependent upon sand content.

Series D6 pump handling crude oil in Argentina



Slop Oil

Slop oil can originate from many sources, making slop oil treatment one of the most technically demanding applications for separation technology.

Slop oil can consist of the following:

0 - 100% Oil

0 - 100% Emulsion

0 - 100% Water

0 - 60% Solids

Waxes are also present, which usually dictates the necessity to process at high temperatures ($>70^{\circ}\text{C}$).

The longer a slop oil is stored the more organic solids (aspheltines etc) will precipitate creating an increase in solids and helping to stabilise the emulsions. Slop oil ponds/tanks may have slop oil which has been stored for over 20 years making it difficult to process.

Lubricating Oil

Lubricating oils are produced in many varieties dependent upon differing applications, ie Cylinder oil, Engine oil, Gearbox oil, Compressor oil, Hydraulic oil and Turbine oil.



Series D6 pump at UK oil terminal used to feed a separator to remove hydrocarbon residues from surface water

General points for careful consideration during selling / pump selection process:

- *Compatibility with metallic and elastomeric pump components?*
- *Abrasive solids present?*
- *Vapour pressure with respect to Net Positive Suction Head required (NPSH)?*
- *Primary seal selection - hazardous nature of media?*

5.7 Photographic Solutions

For pumps handling photographic solutions it is vital that no cross contamination between different batches occurs. The SSP Series X rotary lobe pumps with its EHEDG accreditation are particularly successful in this application.



Series X pump



Film Processing

An emulsion holding grains of photosensitive chemical compounds called silver halides is spread over a film. Light coming through the camera lens from an object being photographed strikes certain areas of the film, rendering the silver halide grains in those areas unstable. This creates an invisible, or latent, image of the object on the film. The areas of the latent image that receive the most light contain the largest number of unstable grains. Upon development they become the darkest areas of the visible image. Conversely, areas that receive little light form the bright parts of the visible image.

Because of the reversal of dark and bright areas from the latent image to the visible image, the visible image is often called a negative. The most common method of making the image visible is to bathe it in a chemical developer that reduces the unstable silver halide grains to black metallic silver, which forms the image. In addition to the reducing agent, which is generally an organic compound such as a phenol or an amine, the typical developer contains additives that cause development to go on at a desired rate, prevent the reducing agent from being destroyed by the air, and keep unexposed silver halide from fogging the film. Each developer is generally designed to be used with particular film emulsions and to produce certain desired effects, such as fineness of grain in the finished image.

After development the negative must be stabilized, or fixed, so that it will no longer be sensitive to light. In fixing, the unexposed silver halide grains are removed by immersion in a water solution of sodium or aluminum thiosulphate. Between the developing and fixing processes the negative may be placed in an acid bath to neutralize excess alkali left by the developer. After fixing, the negative is washed and dried. Next the negative may be subjected either to intensification, a process in which additional silver is deposited in exposed areas to increase the contrast in the image, or to reduction, a process in which silver is removed to decrease the contrast. Toning is a process in which a photographic image is treated to change its colour, as by changing the deposited silver to silver sulphide or causing a coloured metal salt to form along with the silver.

Developers

Film and print developers use several chemical components to react with the exposed silver halide crystals in the emulsion and change them to metallic silver. The developing (or reducing) agent is the primary chemical in the formula. Different agents will have different effects on film or print contrast, graininess, and colour. The most common developing agents are hydroquinone, metol, and phenidone

Developing agents, however, are too weak to work alone. An accelerator (also known as the 'alkali' or 'activator') activates the developing agent. A developer with a strong accelerator will give a quick developing time and higher contrast, but may also lead to excessive fog, soft emulsions, coarse grain, and shorter developer life. Some typical accelerators are, in order of strength, are sodium hydroxide (or potassium hydroxide), sodium carbonate, Kodalk, borax and sodium sulphite. A restrainer is added to reduce chemical fog, which is the development of unexposed silver halide crystals by the developing agent. The restrainer slows the developing action in areas that receive less exposure. Therefore, a developer with a high quantity of restrainer will increase contrast. The type of restrainer will also have an effect on image colour in printing paper. Two chemicals used as restrainers are potassium bromide (most common) and benzotriazole. A preservative, such as sodium sulphite, is often used in developers to prevent oxidation of the chemicals with air.

Fixers

Fixers (also called 'hypo') dissolve the undeveloped silver halide crystals from the film or paper emulsion. Poorly fixed film or prints will stain due to the darkening of the remaining silver halides. Most fixers comprise of a fixing agent, an acid, a preservative, a hardener and a buffer.

The fixing agent is the most active part of the fixer in removing the undeveloped silver halide crystals. Sodium thiosulphate or ammonium thiosulphate is used as fixing agents. Ammonium thiosulphate is used in 'rapid fixers', which fix the film or paper in less time than its sodium counterpart. An acid such as acetic acid stops the developing action and a preservative is included to prevent the disintegration of the fixer by the acid. A hardener such as potassium alum, is usually only used in film development to protect the emulsion from softening and scratches. A buffer, usually boric acid is used to maintain the acidity of the fixer when a hardener is used.

General points for careful consideration during selling / pump selection process:

- *Compatibility with elastomeric pump components?*
- *Temperature sensitive?*
- *Abrasive solids present?*
- *Ultra hygiene of paramount importance - EHEDG?*
- *Pump shaft speed - keep relatively low to avoid high shear rates and excessive wear?*
- *Primary seal selection - hazardous nature of media?*

5.8 Plastics (or Resins)

Plastics, usually referred to as resins, are generally organic high polymers (i.e. they consist of large chainlike molecules containing carbon) that are formed in a plastic state either during or after their transition from a small-molecule chemical to a solid material. Stated very simply, the large chainlike molecules are formed by hooking together short-chain molecules of chemicals (monomers: mono = one, mer = unit) in a reaction known as polymerization (poly = many). When units of a single monomer are hooked together, the resulting plastic is a homopolymer, such as polyethylene, which is made from the ethylene monomer. When more than one monomer is included in the process, for example, ethylene and propylene, the resulting plastic is a copolymer.

The two basic groups of plastic materials are the thermoplastics and the thermosets.

- **Thermoplastics**
Thermoplastic resins consist of long molecules, each of which may have side chains or groups that are not attached to other molecules (i.e. are not crosslinked). Thus, they can be repeatedly melted and solidified by heating and cooling so that any scrap generated in processing can be reused. No chemical change generally takes place during forming.
- **Thermosets**
Thermoset plastics react during processing to form crosslinked structures that cannot be remelted and reprocessed. Thermoset scrap must be either discarded or used as a low-cost filler in other products.

The distinction between thermoplastics and thermosets is not always clear. For example, thermoplastic polyethylene can be extruded as a coating for wire and subsequently crosslinked (either chemically or by irradiation) to form a thermoset material that no longer will melt when heated. Some plastic materials, such as polyester resins, can be both thermoset and thermoplastic.

Plastic Resins

- **Acetal**
This is a thermoplastic produced by the polymerization of purified formaldehyde into both homopolymer and copolymer types.
*Typical application areas - Automotive parts
Consumer products
Industrial machinery parts*
- **Acrylics**
These are a family of thermoplastic resins of acrylic esters or methacrylic esters. The acrylates may be methyl, ethyl, butyl, or 2-ethylhexyl. Usual methacrylates are the methyl, ethyl, butyl, laural and stearyl.
*Typical applications areas - Automotive parts
Glazing
Lighting fixtures*
- **Acrylonitrile-Butadiene-Styrene (ABS)**
Chemically, this family of thermoplastics is called terpolymers, because they are made of three different monomers: acrylonitrile, butadiene and styrene, to create a single material that draws on the best properties of all three.
*Typical application areas - Appliances
Automotive parts
Business machines
Pipe
Telephone components*

- **Alkyds**
Alkds are thermosetting unsaturated polyester resins produced by reacting an organic alcohol with an organic acid, dissolved in and reacted with unsaturated monomers such as styrene, diallyl phthalate, diacetone acrylamide or vinyl toluene.
*Typical application areas - Automotive parts
Coatings*
- **Cellulosics**
Cellulosics are thermoplastic resins manufactured by chemical modification of cellulose. These can be:
Cellophane - regenerated cellulose made by mixing cellulose xanthate with a dilute sodium hydroxide solution to form a viscose, then extruding the viscose into an acid bath for regeneration.
Cellulose acetate - an acetic acid ester of cellulose.
Cellulose acetate butyrate - a mixed ester produced by treating fibrous cellulose with butyric acid, butyric anhydride, acetic acid and acetic anhydride in the presence of sulphuric acid.
Cellulose propionate - formed by treating fibrous cellulose with propionic acid and acetic acid and anhydrides in the presence of sulphuric acid
Cellulose nitrate - made by treating fibrous cellulosic materials with a mixture of nitric and sulphuric acids.
*Typical application areas - Automotive parts
Consumer products
Packaging*
- **Coumarone-Indene**
This is a thermoplastic resin obtained by heating mixtures of coumarone and indene with sulphuric acid to promote polymerization. These resins have no commercial applications when used alone. They are used primarily as processing aids, extenders and plasticizers with other resins in asphalt floor tile.
- **Diallyl Phthalate (DAP)**
The term DAP is used both for the monomeric and polymeric forms. The monomer is used as a cross-linking agent in unsaturated polyester resins. As a polymer, it is used in the production of thermosetting molding powders, casting resins and laminates
- **Epoxy**
These are thermosetting resins that, in the uncured form, contain one or more reactive epoxide or oxirane groups. These epoxide groups serve as cross-linking points in the subsequent curing step, in which the uncured epoxy is reacted with a curing agent or hardener. Cross-linking is accomplished through the epoxide groups as well as through hydroxyl groups that may be present. Most conventional unmodified epoxy resins are produced from epichlorohydrin (chloropropylene oxide) and bisphenol A. The other types of epoxy resins are phenoxy resins, novolac resins, and cycloaliphatic resins.
*Typical application areas - Bonding adhesives
Building and construction
Electrical
Protective coatings
Many other uses*
- **Fluoropolymer**
These make up a family of thermoplastic resins similar to polyethylene in which some of the hydrogen atoms attached to the carbon chain are replaced by fluorine or fluorinated alkyl groups. In some cases, other halogens such as chlorine are also part of the molecule. The most common commercial fluoropolymers are:

- **Polyamide-Imide**
 These are engineering thermoplastic resins produced by the condensation reaction of trimellitic anhydride and various aromatic diamines.
Typical application areas - Aerospace
Automotive
Heavy equipment industries
- **Polyarylates**
 These are engineering thermoplastic resins produced by interfacial polymerization of an aqueous solution of the disodium salt of bisphenol A with phthalic acid chlorides in methylene chloride.
Typical application areas - Outdoor lighting
- **Polybutylene**
 These are thermoplastic resins produced via stereospecific Ziegler-Natta polymerization of butene-1 monomer.
Typical application areas - Packaging film
Pipe
- **Polycarbonate**
 These are engineering thermoplastic resins that can be produced in three ways

 - phosgenation of dihydric phenols, usually bisphenol A
 - ester exchange between diaryl carbonates and dihydric phenols, usually between diphenyl carbonate and bisphenol A
 - interfacial polycondensation of bisphenol A and phosgene.
 Polycarbonates are transparent and can be processed in a variety of ways, including injection moulding, extrusion, blow moulding and rotational moulding.
Typical application areas - Appliances
Electrical
Glazing
- **Polyethylene**
 These are thermoplastic resins obtained by polymerizing the gas ethylene. Low molecular weight polymers of ethylene are fluids used as lubricants; medium weight polymers are waxes miscible with paraffin; and the high molecular weight polymers are the materials used in the plastics industry. Polymers with densities ranging from about 0.910 to 0.925 are called low density; those of densities from 0.926 to 0.940 are called medium density; and those from 0.941 to 0.965 and over are called high density. The low density types are polymerized at very high pressures and temperatures, and the high density types at relatively low temperatures and pressures.
Typical application areas - Communication equipment
Housewares
Packaging
Toys
- **Polyimides**
 These are a family of thermoset and thermoplastic resins characterized by repeating imide linkages.
Typical application areas - Electrical
Transportation
- **Polyphenylene Oxide, Modified**
 These are engineering thermoplastic resins produced by the oxidative coupling of 2, 6-dimethylphenol (xylenol), then blended with impact polystyrene.
Typical application areas - Appliances
Automotive parts
Business machine parts
Electrical

- **Polyphenylene Sulfide**
 These are engineering thermoplastic resins produced by the reaction of p-dichlorobenzene with sodium sulfide.
*Typical application areas - Automotive parts
 Electrical*
- **Polypropylene**
 These are thermoplastic resins made by polymerizing propylene and in the case of copolymers with monomers, with suitable catalysts, generally aluminum alkyl and titanium tetrachloride mixed with solvents.
*Typical application areas - Appliances
 Automotive parts
 Carpeting
 Packaging*
- **Polystyrene**
 These are high molecular weight thermoplastic resins produced generally by the free-radical polymerization of styrene monomer which can be initiated by heating alone but more effectively by heating in the presence of free-radical initiator, such as benzoyl peroxide. Typical processing techniques are modified mass polymerization or solution polymerization, suspension polymerization, and expandable beads for foam.
*Typical application areas - Building and construction
 Consumer products
 Electrical*
- **Polyurethane**
 These are a large family of polymers based on the reaction product of an organic isocyanate with compounds containing a hydroxyl group. The commonly used isocyanates for manufacturing polyurethanes are toluene diisocyanate, methylene diphenyl isocyanate, and polymeric isocyanates, obtained by the phosgenation of polyamines derived from the condensation of aniline with formaldehyde. They are extremely versatile plastics in terms of the forms in which they are available i.e. flexible or rigid foams, solid elastomers, coatings, adhesives and sealants. Polyurethane foams are widely used in transportation, furniture and construction markets.
- **Polyvinyl Acetate (PVA)**
 This is a thermoplastic resin produced by the polymerization of vinyl acetate monomer in water producing an emulsion with a solids content of 50-55%. Most polyvinyl acetate emulsions contain co-monomers such as n-butyl acrylate, 2-ethyl hexyl acrylate, ethylene, dibutyl maleate and dibutyl fumarate. Polymerization of vinyl acetate with ethylene also can be used to produce solid vinyl acetate/ethylene copolymers with more than 50% vinyl acetate content.
*Typical application areas - Adhesives
 Coatings and finishes
 Packaging
 Paints*
- **Polyvinyl Chloride (PVC)**
 These are thermoplastic resins produced by the polymerization of the gas vinyl chloride. Under pressure, vinyl chloride becomes liquified and is polymerized by one of four basic processes: suspension, emulsion, bulk, or solution polymerization. The pure polymer is hard, brittle and difficult to process, but it becomes flexible when plasticizers are added.
*Typical application areas - Building and construction
 Consumer products
 Electrical
 Packaging*

- **Styrene Acrylonitrile**
 These are thermoplastic copolymers of styrene and acrylonitrile. Styrene Acrylonitrile resins are random, amorphous copolymers produced by emulsion, suspension, or continuous mass polymerization.
*Typical application areas - Automotive instrument panels and interior trim
 Housewares*
- **Styrene Butadiene Latexes and Other Styrene Copolymers**
 Styrene butadiene latexes usually have a resin content of about 50%. The styrene/butadiene ratio varies from 54:46 to 80:20. Most are carboxylated by the use of such acids as maleic, fumaric, acrylic, or methacrylic. Acrylic monomers are also used in conjunction with styrene to produce specialty resins. Styrene butadiene latexes are used in carpet backing and paper coatings. The other styrenics are used in paints, coatings, and floor polishes, plus many other uses.
- **Sulfone Polymers**
 These are a family of engineering thermoplastic resins characterised by the sulfone group. Polysulfone is made by the reaction of the disodium salt of bisphenol A with 4,4'-dichlorodiphenyl sulfone 4,4'-DCDPS. Polyethersulfone is made by the reaction of 4,4'-DCDPS with potassium hydroxide. Polyphenylsulfone is similar to the other sulfone polymers.
*Typical application areas - Automotive parts
 Electrical*
- **Thermoplastic Polyester (Saturated)**
 These form a family of thermoplastic polyesters in which the polyester backbones are saturated and hence unreactive. The most common commercial types are:

 - Polyethylene terephthalate produced by polycondensation of ethylene glycol with either dimethyl terephthalate or terephthalic acid.
 - Polybutylene terephthalate produced by the reaction of dimethyl terephthalate with 1,4 butanediol.*Typical application areas - Automotive
 Consumer markets
 Electrical
 Packaging*
- **Unsaturated Polyester**
 These are thermosetting resins made by the condensation reaction between difunctional acids and glycols. The resulting polymer is then dissolved in styrene or other vinyl unsaturated monomer. The structures of the acids and glycols used and their proportions, especially the ratio of the unsaturated versus the saturated acid, and the type and amount of monomer used, are all tailored for each resin to balance economy, processing characteristics, and performance properties.
*Typical application areas - Appliances
 Construction markets
 Electrical
 Transportation*
- **Urea-Formaldehyde**
 These are thermoset resins that are clear water-white syrups or white powdered materials, which can be dispersed in water to form colourless syrups. They cure at elevated temperatures with appropriate catalysts. Moulding powders are made by adding fillers to the uncured syrups, forming a consistency suitable for compression and transfer moulding. The liquid and dried resins find extensive uses in laminates and chemically resistant coatings. The moulding compounds are formed into rigid electrical and decorative products.

General points for careful consideration during selling / pump selection process:

- *Compatibility with elastomeric pump components?*
- *Temperature sensitive?*
- *Abrasive solids present?*
- *High viscosity?*
- *Pump shaft speed - keep relatively low to avoid high shear rates and excessive wear?*
- *Primary seal selection - hazardous and solidifying nature of media?*

5.9 Printing Inks

Ink is an organic or inorganic pigment or dye dissolved or suspended in a solvent - essentially similar to paint. Inks are divided into two types: printing inks and writing inks. Printing inks are further broken down into two subgroups: ink for conventional printing, in which a mechanical plate comes in contact with or transfers an image to the paper or object being printed on; and ink for digital non-impact printing, which includes ink-jet and electrophotographic technologies.

Color printing inks are made primarily with linseed oil, soybean oil, or a heavy petroleum distillate as the solvent combined with organic pigments. The pigments are made up of salts of multi-ring nitrogen-containing compounds (dyes). Black ink is made using carbon black. And white pigments, such as titanium dioxide, are used either by themselves or to adjust characteristics of color inks. Inks also contain additives such as waxes, lubricants, surfactants, and drying agents to aid printing and to impart any desired special characteristics.

Printing ink is a 10 billion dollar global industry. Older style writing inks, such as in fountain pens, use a fluid water-based dye system. But in the 1950s, when ballpoint pens became fashionable, the writing ink industry shifted to paste like oil-based dye systems. The thick consistency allows capillary action to keep the ink flowing well, and the inks generally are non-smearing and quicker drying than water-based systems. Dyes tend to be preferred over pigments for writing inks because pigments cannot be dispersed minutely enough and tend to clog the pen tip. Water-based dye or pigment systems are still used for markers, highlighters, and rollerball pens.

In general terms, pumps constructed in 316L stainless steel will be compatible for all types of ink. However for printing ink due to its slightly abrasive nature, Series D and G ductile iron pumps should be considered.



Series D4 pump handling UV resin with Series S3 pump handling water-base ink in background at printing ink plant in UK

General points for careful consideration during selling / pump selection process:

- *Compatibility with metallic and elastomeric pump components?*
- *Temperature sensitive?*
- *Abrasive solids present?*
- *High viscosity?*
- *Pump shaft speed - keep relatively low to avoid high shear rates and excessive wear?*
- *Primary seal selection - hazardous and solidifying nature of media?*

5.10 Solvents

A solvent is a liquid that can dissolve another material. In industry the term solvent is generally applied to the kinds of substances known as 'organic solvents' (carbon containing) that are widely used to dissolve organic chemicals such as oils and resins. Water is a solvent, but is 'inorganic' (does not contain carbon) Examples of organic solvents include kerosene, acetone, petroleum distillates and naphthas. Potential solvent uses are limitless and include degreasing, cleaning, stripping, thinning and finishing.

Organic solvents can be split into three groups by their chemical structure:

Oxygenated solvents

Major types are alcohols, glycol ethers, ketones, esters and glycol ether esters as listed below with their uses.

- **Acetate esters:**
Ethyl Acetate, n-Butyl Acetate, Iso Butyl Acetate and Isopropyl Acetate used in detergents, pharmaceutical, cosmetics, coatings, and inks applications.
- **Glycol ethers:**
Butyl Diglycol Ether, Butyl Glycol Ether, Methoxypropanol, Ethoxypropanol used in consumer goods, cosmetics, coatings and inks applications.
- **Glycol ether esters:**
These include Butyl Glycol Acetate, Ethoxypropyl Acetate, Methoxypropyl Acetate and Butyl Diglycol Acetate used in industrial coatings and inks applications.
- **Alcohols:**
These include Isopropanol used in coating, inks, consumer goods, adhesives, detergents, pharmaceuticals and medical applications.

Hydrocarbon solvents

Major types are aliphatic and aromatic hydrocarbons as listed below with their uses.

- **Aliphatics:**
These include paraffinic solvents such as Hexane, Benzene and Kerosine, which have a low aromatic content. Industrial applications include oil extraction, rubber, paints, degreasing, carriers for aerosols, and disinfectants.
- **Low aromatics:**
These include White Spirits and Turpentine used in the paint industry, the manufacture of high grade waxes and polishes, use in the uranium extraction process, coal benification, dry cleaning, and metal cutting operations
- **High aromatics**
These include Toluene and Xylene used in compounded products for degreasing (thinners), paints, printing inks, insecticides and agricultural chemicals.

Chlorinated solvents

Major types are:

- **Perchloroethylene**
Used in dry and metal cleaning applications.
- **Trichloroethylene**
Used in metal cleaning applications.
- **Methylene Chloride**
Used in pharmaceutical, electrical and paint stripping applications.

Solvents do not necessarily require the use of pumps manufactured from stainless steel - in many cases Series D ductile iron pumps should be considered.

Series S4 pump handling solvents at UK chemical plant



General points for careful consideration during selling / pump selection process:

- *Compatibility with metallic and elastomeric pump components?*
- *Vapour pressure with respect to Net Positive Suction Head required (NPSHr)?*
- *Primary seal selection - hazardous nature of media?*

6.0 Pump Selection and Application Summary

This section gives information as to pump selection for different pumped media found in the Chemical Industry.

It should be noted that the information given in this section is for guidance purposes only - actual pump selection should be verified by our Technical Support after the provision of full pumped media and duty details.

Chemical Applications Summary

Viscosity applicable in pump
 low = <50 cP
 med = 50 - 1000 cP
 high = >1000 cP

Pump Speed
 low = <100 rpm
 med = 100 - 350 rpm
 high = >350 - max rpm pump speed

Media	Viscous Behaviour Type	Viscosity	Speed	Pump Series	Sealing	Elastomer Compatibility	Comments
ACETIC ACID	Newtonian	low	high	S, A	see comment	EPDM, PTFE	Seal selection dependent upon temperature and concentration
ACETONE	Newtonian	low	high	S, X, L, D, N, M	Single	EPDM, PTFE	
ADHESIVE - SOLVENT BASED	Pseudoplastic	high	med	S, A	Single Flush	PTFE	
ADHESIVE - WATER BASED	Pseudoplastic	med	med	S, L, A	Single Flush	EPDM, PTFE	
ALKYD RESIN	Pseudoplastic	high	med	S, L, D	Single Flush	FPM, PTFE	
AMMONIUM HYDROXIDE	Newtonian	low	high	S, A	see comment	EPDM	Seal selection dependent upon temperature and concentration
ANTI-FOAM	Pseudoplastic	high	med	S, L, A	Single	EPDM, FPM	
BENTONITE SUSPENSION	Pseudoplastic	med	med	S, L, A	Single Flush	NBR, EPDM, FPM, PTFE	Fluid can become dilatant at high concentration and shear rate
BLEACH	Newtonian	low	high	S, L, A	see comment	EPDM, FPM, PTFE	Seal selection dependent upon temperature and concentration
BRAKE FLUID	Newtonian	low	high	S, L, A, G, D	Single	EPDM, PTFE	
CALCIUM CARBONATE SLURRY	Pseudoplastic	high	med	S, L, A	Single	NBR, EPDM, FPM, PTFE	
CELLULOSE ACETATE DOPE	Pseudoplastic	high	low	S, A	Single Flush	PTFE	
CELLULOSE SUSPENSION	Pseudoplastic	low	med	S, L, A	Single Flush	NBR, EPDM, FPM, PTFE	
CHROMIC ACID	Newtonian	low	high	S, A	Double	FPM, PTFE	
CRUDE OIL	Pseudoplastic	med	med	D, G	Single Flush	FPM, PTFE	
DETERGENT - AMPHOTERIC	Newtonian	med	med	S, X, L, A	Single Flush	FPM, PTFE	
DETERGENT - ANIONIC	Pseudoplastic	med	med	S, X, L, A	Single Flush	NBR, EPDM, FPM, PTFE	If low concentration this can be Newtonian
DETERGENT - CATIONIC	Newtonian	med	med	S, X, L, A	Single Flush	FPM, PTFE	
DETERGENT - NONIONIC	Newtonian	med	med	S, X, L, A	Single Flush	EPDM, FPM, PTFE	
DIESEL OIL	Newtonian	low	high	S, L, A, G, D	Single	NBR, FPM, PTFE	
DISHWASH LIQUIDS	Pseudoplastic	med	med	S, X, L, A	Single	FPM, PTFE	If low concentration this can be Newtonian
DODECYL BENZENE SULPHONIC ACID	Newtonian	high	med	S, X, L, A	Single Flush	FPM, PTFE	
DYE	Newtonian	low	high	S, L, A, G, D, M	Single	EPDM, FPM, PTFE	
ETHANOL	Newtonian	low	high	S, X, L, D, N, M	Single	NBR, EPDM, PTFE	
ETHYLENE GLYCOL	Newtonian	low	high	S, L, A, N, M	Single	NBR, EPDM, FPM, PTFE	
FABRIC CONDITIONER	Pseudoplastic	low	high	S, X, L, A	Single	FPM, PTFE	
FERRIC CHLORIDE	Newtonian	low	med	S, A	see comment	NBR, EPDM, FPM, PTFE	Seal selection dependent upon temperature and concentration
FILTER AID	Pseudoplastic	med	med	S, L, A	Single Flush	NBR, EPDM, FPM, PTFE	
FIRE FIGHTING FOAM	Pseudoplastic	low	med	S, L, A	Single	FPM, PTFE	
FORMIC ACID	Newtonian	low	high	S, A	see comment	EPDM, PTFE	Seal selection dependent upon temperature and concentration
GREASE	Pseudoplastic	med	med	S, L, A, G, D	Single	NBR, FPM, PTFE	
HYDROCHLORIC ACID	Newtonian	low	high	S, A	see comment	FPM, PTFE	Seal selection dependent upon temperature and concentration. Consideration for special materials.
HYDROFLUORIC ACID	Newtonian	low	high	S, A	see comment	FPM, PTFE	Seal selection dependent upon temperature and concentration. Consideration for special materials.
HYDROGEN PEROXIDE	Newtonian	low	med	S, A	see comment	FPM, PTFE	Seal selection dependent upon temperature and concentration
INK - PRINTING	Pseudoplastic	high	med	S, A, G, D	Double	FPM, PTFE	
INK - WATER BASED	Newtonian	med	high	S, L, A	Single Flush	EPDM, FPM, PTFE	
ISOBUTYL ALCOHOL	Newtonian	low	high	S, X, L, D, N, M	Single	EPDM, FPM, PTFE	
ISOCYANATE	Newtonian	low	med	S, A	Double	PTFE	
ISOPROPANOL	Newtonian	low	high	S, X, L, D, N, M	see comment	EPDM, FPM, PTFE	Seal selection dependent upon temperature and concentration
KEROSENE	Newtonian	low	high	S, L, G, D, N, M	Single	NBR, FPM, PTFE	
LATEX	Pseudoplastic	high	low	S, L, A	Single Flush	EPDM, PTFE	
LUBRICATING OIL	Newtonian	med	high	S, L, A	Single	FPM	

Chemical Applications Summary

Viscosity applicable in pump
 low = <50 cP
 med = 50 - 1000 cP
 high = >1000 cP

Pump Speed
 low = <100 rpm
 med = 100 - 350 rpm
 high = >350 - max rpm pump speed

Media	Viscous Behaviour Type	Viscosity	Speed	Pump Series	Sealing	Elastomer Compatibility	Comments
MANGANESE NITRATE	Newtonian	low	high	S, L, A	Single Flush	FPM, PTFE	
METHANOL	Newtonian	low	high	S, X, L, D	Single Flush	NBR, EPDM, PTFE	
METHYL ETHYL KETONE SOLVENT	Newtonian	low	high	S, X, L, D	Single Flush	EPDM, PTFE	
METHYLATED SPIRIT	Newtonian	low	high	S, X, L, D, N, M	Single	NBR, EPDM, PTFE	
METHYLENE CHLORIDE	Newtonian	low	high	S, A	Double	FPM, PTFE	
NITRIC ACID	Newtonian	low	high	S, A	see comment	FPM, PTFE	Seal selection dependent upon temperature and concentration
PAINTS - WATER BASED	Pseudoplastic	low	med	S, L, A	Single Flush	NBR, EPDM, FPM, PTFE	
PAINTS - OIL BASED	Pseudoplastic	high	med	S, A, G, D	Single Flush	PTFE	
PETROLEUM	Newtonian	low	high	S, L, G, D, N, M	Single	NBR, FPM, PTFE	
PHOSPHORIC ACID	Newtonian	low	high	S, A	see comment	EPDM, PTFE	Seal selection dependent upon temperature and concentration
PHOTOGRAPHIC EMULSION	Pseudoplastic	low	med	S, X	Double	EPDM, FPM, PTFE	
PLASTISOL	Newtonian	med	med	S, L, A	Single Flush	EPDM, PTFE	
POLYETHYLENE GLYCOL	Newtonian	low	high	S, X, L, D, N, M	Single	EPDM, FPM, PTFE	
POLYOL	Pseudoplastic	high	med	S, L, A	Single Flush	FPM, PTFE	
POLYVINYL ACETATE	Pseudoplastic	high	med	S, A	Double	EPDM, FPM, PTFE	
POLYVINYL ALCOHOL	Pseudoplastic	med	med	S, L, A	Single Flush	EPDM, FPM, PTFE	
POTASSIUM HYDROXIDE	Newtonian	low	med	S, L, A	see comment	EPDM, PTFE	Seal selection dependent upon temperature and concentration
PROPIONIC ACID	Newtonian	low	high	S, A	Double	PTFE	
PROPYLENE GLYCOL	Newtonian	low	high	S, L, N, M	Single	NBR, EPDM, FPM, PTFE	
PVC PASTE	Pseudoplastic	high	med	S, L, A	Single Flush	FPM, PTFE	
RESIN	Newtonian	high	med	S, D	Double	FPM, PTFE	
RUBBER SOLUTION	Pseudoplastic	med	med	S, A	Single Flush	PTFE	
SILICONE OIL	Pseudoplastic	high	low	S, L, A	Single	NBR, EPDM, FPM, PTFE	
SLOP OIL	Pseudoplastic	med	med	S, L, A	Single Flush	FPM, PTFE	
SODIUM ALKYL ETHER SULPHATE 70%	Pseudoplastic	med	med	S, X, L, A	Single Flush	FPM	
SODIUM HYDROXIDE	Newtonian	low	med	S, L, A	Single Flush	EPDM, PTFE	
SODIUM LAURYL ETHER SULPHATE 27%	Pseudoplastic	low	med	S, X, L, A	Single	FPM	
SODIUM LAURYL ETHER SULPHATE 70%	Pseudoplastic	med	med	S, X, L, A	Single Flush	FPM	
SODIUM SILICATE	Newtonian	high	med	S, L, A	Single Flush	EPDM, FPM, PTFE	
STEARIC ACID	Pseudoplastic	med	high	S, L, A	Single	FPM, PTFE	
SULPHURIC ACID	Newtonian	low	high	S, A	Double	FPM, PTFE	Seal selection dependent upon temperature and concentration. Consideration for special materials.
TALL OIL	Newtonian	med	med	S, L, A	Single Flush	FPM, PTFE	
TITANIUM DIOXIDE	Pseudoplastic	low	med	S, A	Double	NBR, EPDM, FPM, PTFE	Fluid can be become dilatant at high concentration and shear rate
TOBACCO FLAVOURING	Newtonian	low	high	S, L, N	Single	EPDM	
TOLUENE	Newtonian	low	high	S, X, L, D	Single Flush	FPM, PTFE	
TRI-ETHANOLAMINE	Newtonian	med	high	S, X, D	Single	PTFE	
UREA	Newtonian	low	high	S, D	Double	EPDM, FPM, PTFE	
VARNISH	Newtonian	med	med	S, A	Double	PTFE	
VASELINE	Pseudoplastic	med	med	S, L, A	Single	NBR, FPM, PTFE	
VISCOSE	Pseudoplastic	high	low	S, L, D	Single	FPM, PTFE	
WAX	Newtonian	low	med	S, L, A	Single Flush	FPM, PTFE	
XYLENE	Newtonian	low	high	S, X, L, D, N, M	Single	FPM, PTFE	

Alfa Laval Ltd
SSP Pumps
Birch Road, Eastbourne
East Sussex BN23 6PQ, England
Tel: +44 (0) 1323 414600
Fax: +44 (0) 1323 412515
www.sspumps.com

B/301/0811