

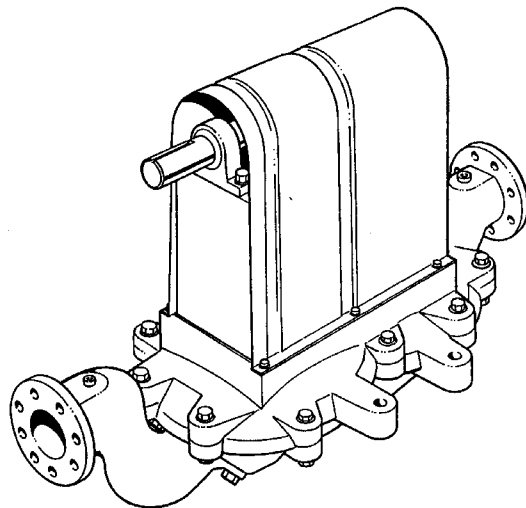

# Dual Disc

Cast Iron Positive Displacement Mechanical Diaphragm Pumps

Operating Manual



# Alfa Laval

Birch Road, Eastbourne,  
East Sussex BN23 6PQ

Tel No : (01323) 412555 Fax (01323) 412515

## EC DECLARATION OF INCORPORATION

We hereby declare that the following machinery is intended for installation into a machine or to be assembled with other machines into a machine. It must **not** be put into service until the machinery into which it is incorporated has been declared in conformity with the provisions of the Machinery Directive 89/392/EEC, amendments 91/368/EEC, 93/44/EEC, 93/68/EEC.

Machine Description DD50 / DD75 PS / DD100 PS Dual Disc Pumps

Type/Size \_\_\_\_\_

Serial Number \_\_\_\_\_

This machinery has been designed and manufactured in accordance with the following transposed harmonised European Standards:-

EN809 : 1998 Pumps and pump units for liquids - common safety requirements

ISO9001: 2000 Quality Management System.

A technical construction file for this machinery is retained at the above address.

Signed  Date \_\_\_\_\_  
(Authorised Person)

Name P. SWEET Position QUALITY MANAGER

# Alfa Laval

Birch Road, Eastbourne,  
East Sussex BN23 6PQ

Tel No : (01323) 412555 Fax (01323) 412515

## EC DECLARATION OF CONFORMITY

We hereby declare that the following machinery conforms to the machinery directive 89/392/EEC as amended by 91/368/EEC, 93/44/EEC and 93/68/EEC and to the following other relevant directives. The machinery has been designed and manufactured in accordance with the transposed harmonised European standards; European and national standards as listed:

Machine Description DD50 / DD75 PS / DD100 PS Double Disc Pumps - Motorised

Type/Size \_\_\_\_\_ Serial Number \_\_\_\_\_

Other Applicable Directives Electrical Equipment Low Voltage 73/23/EEC

Electromagnetic Compatibility 89/336/EEC

Applicable Standards/Specifications \_\_\_\_\_

EN809 : 1998 Pumps and pump units for liquids - common safety requirements

ISO9001 : 1994 Quality Management System.

A technical construction file for this machinery is retained at the above address.

Signed  Date \_\_\_\_\_  
(Authorised Person)

Name P. SWEET Position QUALITY MANGER



## Contents

---

	Page No
<b>1.0 General</b>	
1.1 Pump limits of application or use	1
1.2 Duty conditions	1
1.3 Noise levels	1
1.4 Utility requirements	1
1.5 Safety precautions	2
1.6 Health and safety information	3
<b>2.0 Unpacking, handling and storage</b>	
2.1 Documents	4
2.2 Unpacking	4
2.3 Handling	4
2.4 Pump storage	5
<b>3.0 Description of pump or pump unit</b>	
3.1 General pump description	6
3.2 Principle of operation	6
3.3 Pump dimensions	7
3.4 Pump and pump unit weights	7
3.5 Pump capacities	7
<b>4.0 System design and installation</b>	
4.1 System design advice	8
4.2 Pump and base foundations	9
4.3 Installation	9
4.4.1 Coupling alignment (metric)	10
4.4.2 Coupling alignment (imperial)	11
4.5.1 Pulley belt tension adjustment (metric)	12
4.5.2 Pulley belt tension adjustment (imperial)	13
4.6 Pipework	14
4.7 Recommended layout for suction lift	15
4.8 Pulsation	15
<b>5.0 Commissioning</b>	
5.1 Lubrication	16
<b>6.0 Start up, shut down and cleaning in place</b>	
6.1 Pump start-up check list	17
6.2 Priming the pump	18
6.3 Pump shut down procedure	18

# Operating Manuals

## Contents

---

	<b>Page No</b>
<b>7.0 Maintenance and inspection</b>	
7.1 Maintenance schedule	19
7.2 Recommended spares	19
<b>8.0 Disassembly</b>	
8.1 Before dismantling the pump	20
8.2 Dismantling the DD50 dual disc pump	21
8.3 Dismantling the DD50 dual disc drive shaft assembly	22
8.4 Dismantling the DD75 PS dual disc pump from the mounting frame	23
8.5 Dismantling the DD75 PS dual disc pump	24
8.6 Dismantling the DD75 PS dual disc pump drive shaft assembly	25
8.7 Dismantling the DD100 PS dual disc pump from mounting frame	26
8.8 Dismantling the DD100 PS dual disc pump	27
8.9 Dismantling the DD100 PS dual disc pump drive shaft assembly	28
<b>9.0 Assembly</b>	
9.1 Assembly of the DD50 dual disc pump drive shaft assembly	29
9.2 Assembly of the DD50 dual disc pump	30-31
9.3 Assembly of the DD75 PS dual disc pump drive shaft assembly	32
9.4 Assembly of the DD75 PS dual disc pump	33
9.5 Assembly of the DD75 PS dual disc pump and drive on frame	34
9.6 Assembly of the DD100 PS dual disc pump drive shaft assembly	35
9.7 Assembly of the DD100 PS dual disc pump	36
9.8 Assembly of the DD100 PS dual disc pump and drive frame	37
<b>10.0 Faults, causes and remedies</b>	38
<b>11.0 Technical data</b>	
11.1 Pump information chart	39
11.2 Torque specification chart	40
<b>12.0 Exploded pump drawing and parts list</b>	
12.1 DD50 dual disc pump	41
12.2 DD75 PS dual disc pump	42
12.3 DD100 PS dual disc pump	43

### **1.0 General**

---

#### **1.1 Pump limits of applications or use**

This range of pumps has been designed for pumping a variety of media, slurries, sludges, large suspended solids, thixotropic materials and liquid/gel mixtures.

Pressures of up to 3 bar (43.5 psi), speeds to 750rpm depending on pump size and temperatures to 50°C can be obtained.

For specific guidelines contact your supplier quoting :- pump model, serial number and system details (e.g. product, pressure, flow rate).

#### **1.2 Duty conditions**

The Pump should only be used for the duty for which it has been specified. The operating pressure, speed and temperature limits have been selected at the time of order and **MUST NOT** be exceeded for the pump. These details are stated on the original documentation and if not available may be obtained from your supplier quoting :- pump model and serial number.

#### **1.3 Noise levels**

Under certain operating conditions pumps and/or drives and/or the systems within which they are installed, can produce sound pressure levels in excess of 85dB[A]. When necessary personal protection against noise should be taken to safeguard the hearing of persons who are likely to be in close proximity to the equipment.

Please consult **Alfa Laval Pumps Ltd** for further information if necessary.

#### **1.4 Utility requirements**

##### **Electrical supply :-**

This pump may be supplied bareshaft or coupled to a drive unit for which a drive unit/ electrical supply will be required. The pump may also be driven by a diesel drive unit.

# Operating Manuals

## 1.5 Safety requirements

All warnings in this manual are summarised on this page.

Pay special attention to the instructions below so that severe personal injury or damage to the pump can be avoided.

Personnel performing installation, operation and maintenance of the pump must have the relevant experience required.

## Warnings signs:



General safety instructions are preceded by this symbol.



Electrical safety instructions are preceded by this symbol.



Take great care when using caustic agents.

### Installation



: **Always** observe the technical data.



: The pump **must** be electrically connected by authorised personnel. (See the motor instructions supplied with the drive unit).



: **Never** put your hands or fingers inside the port connections

### Operation



: **Always** observe the technical data.



: **Never** touch the pump or the pipelines when pumping hot liquids.



: **Never** stand on the pump or pipelines.



: **Never** run the pump with both the suction side and the pressure side blocked.



: **Always** handle toxic and acidic liquids with great care.



: **Never** put your hands or fingers inside the port connections.

### Maintenance



: **Always** observe the technical data.



: **Always** disconnect the pump from the drive unit and power supply when servicing the pump.



: The pump must **never** be hot when servicing it.



: The pump and pipelines must **never** be pressurised when servicing the pump.



: **Never** put your hands or fingers inside the port connections.

**Study this manual carefully**

## 1.6 Health and safety information

### Potential safety hazards

The following section gives information on handling, storage and disposal of parts and materials used in the pumps which may be considered hazardous to health.

Please pass this information on to your Safety Officer, he may need it to comply with Health and Safety, and COSHH (OSHA) regulations.

Electric motors - the pump may have an electric motor fitted, ensure that the relevant fire equipment is available.

The information contained here is brief.

### General first aid

If potentially hazardous substances are accidentally inhaled, or skin or eyes contaminated, then the following basic precautions should be taken

Inhalation - Remove to fresh air

Skin - Wash with soap and water

Eyes - Flush with water, seek medical attention

In all cases, if symptoms persist, seek medical attention.

Material	Use	Major Hazard
ADHESIVES	SUCTION AND DISCHARGE GASKETS	RELEASES VAPOUR AT ROOM TEMPERATURE
GREASE	GENERAL LUBRICATION	SKIN AND EYE IRRITANT
ELASTOMER COMPOUNDS (EPDM, VITON, NITRILE)	'O' RINGS, TRUNNIONS SUCTION/ DISCHARGE DISCS, CHECK VALVE, SUCTION/DISCHARGE GASKETS.	RELEASE FUMES WHEN HEATED.
ANTI-SEIZE COMPOUNDS	BEARINGS	APPLIED FROM AEROSOL RELEASES VAPOUR, DISPOSE OF CONTAINER AS IF PRESSURISED.
PAINT	EXTERNAL PUMP SURFACES	RELEASES DUST AND FUMES IF MACHINED. TREAT WASTE AS A FIRE HAZARD.

## Operating Manuals

### 2.0 Unpacking, handling and storage

To avoid any problems, on receipt of your pump always use the following procedure:-

#### 2.1 Documents

1. Check the delivery note against the goods received.
2. Check if the pump has been delivered with an electric motor that the motor instructions are available.

#### 2.2 Unpacking

Care must be taken when unpacking the pump, and the following stages must be completed:-

1. Inspect the packing for any possible signs of damage in transit.
2. Carefully remove the packing away from the pump.
3. Inspect the pump for any visible signs of damage.
4. Clean away the packing from the pump port connections.
5. Ensure that any additional equipment such as seal flushing pipework is not damaged.

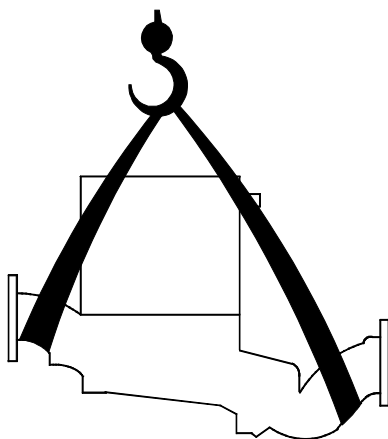

**Bareshaft pump**

#### 2.3 Handling

Refer to the pump weights guide, prior to using any lifting gear. Use the correct lifting slings for the pump weight (or pump and drive if applicable).

The following details show how the pumps should be lifted.

**Bareshaft pump** :- the slings should be wrapped around the ports. The bareshaft pump is not self supporting and will require laying on its side when transported.

**Pump with drive unit** :- the slings should be positioned as shown, around each corner of the base frame.

**Note** :- To stop the slings slipping always cross them at the hook.

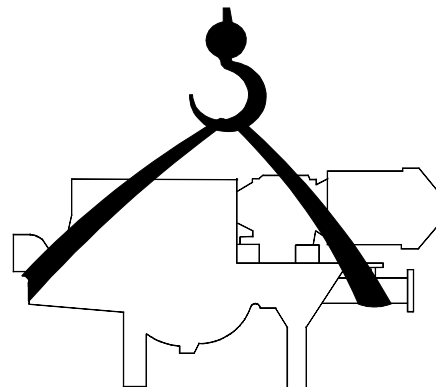

**Pump drive unit with DD50**

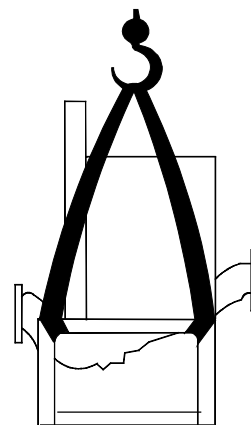

**Pump drive unit with DD75 PS and DD100 PS**

### 2.4 Pump storage

After receipt and inspection if the pump is not to be installed immediately the pump should be repacked and placed in suitable storage. The following points should be noted:-

1. Plastic or gasket type port covers should be left in place.
2. Pumps received wrapped with corrosion inhibiting treatment material should be rewrapped.
3. A clean, dry, vibration free location should be selected. If stored in a moist atmosphere, further protect the pump or unit with a moisture repellent cover until it is to be installed.
4. Rotate pump/pump unit by hand, weekly, to prevent bearing damage.
5. All associated ancillary equipment should be treated similarly.

# Operating Manuals

## 3.0 Description of pump or pump unit

### 3.1 General pump description

The pump supplied is a positive displacement pump, which may be supplied with or without a drive unit (see below). The drawing below indicates various parts of the pump.

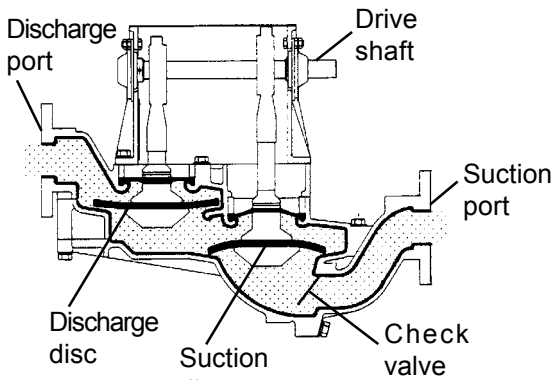

**DD50 and DD75 PS**

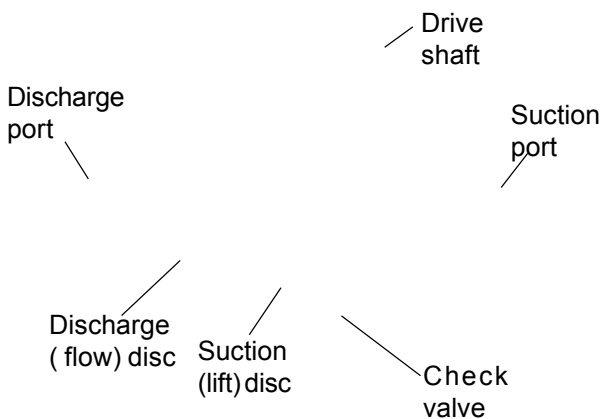

**DD100 PS**

### 3.2 Principle of operation

The pumping principal of the Dual Disc Pump is best explained with reference to diagrams (A) & (B). The pump has three areas through which the product flows, the suction, intermediate and discharge housings. Within the intermediate and discharge housings are two rubber diaphragm, which are each located at the end of their own separate drive rods. A difference in drive rod length along with the two cams located on the drive shaft provide a reciprocating cycle as the shaft is rotated.

At one end of the pumping cycle (A) a large cavity is created in the intermediate chamber pulling in product as it opens, whilst the other end is sealed by the diaphragm closing down. Then as the suction inlet is closed (B) the discharge diaphragm moves upwards and the product flows out. The pumping cycle produces a positive suction and discharge sequence.

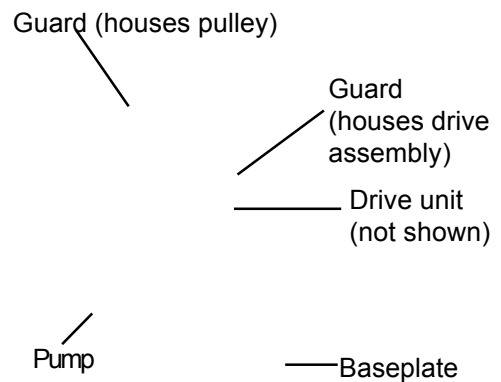

**DD75 PS and DD100 PS**

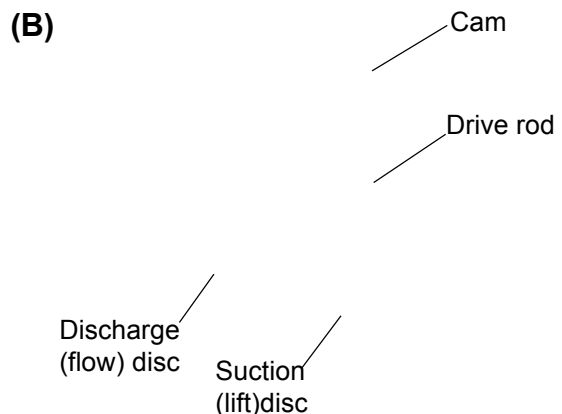
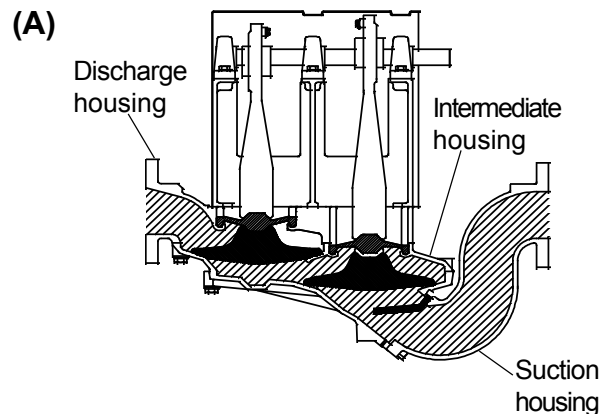

### 3.3 Pump dimensions

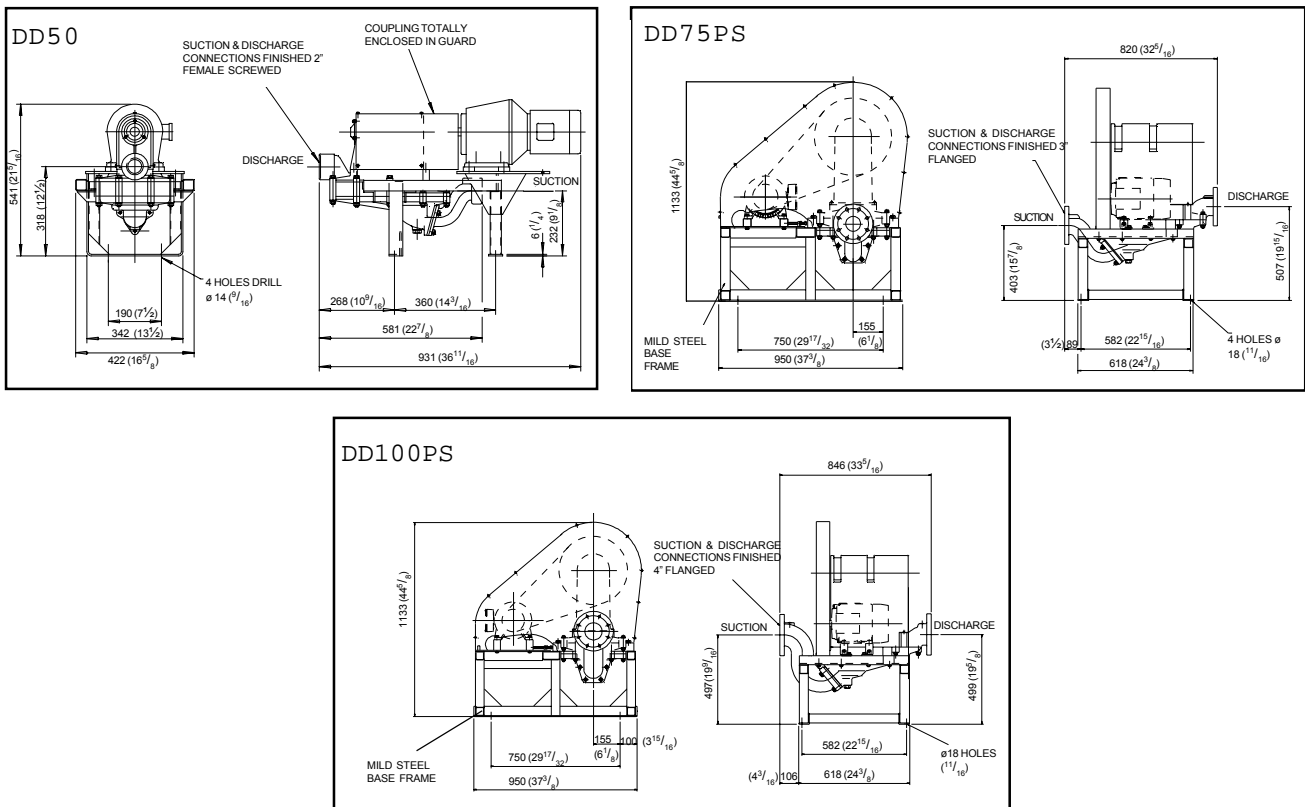

The above dimensions are for guidance only and should not be used for installation purposes. Certified dimensions available upon request.

**NB:** Dimensions shown in brackets ( ) are in inches.  
Dimensions shown without brackets are in millimetres.

### 3.4 Pump and pump unit weights

Pump model	Bareshaft pump KG (LB)	Pump with drive unit KG (LB)
DD50	28 (62)	150 (331)
DD75 PS	122 (269)	250 (551)
DD100 PS	134 (295)	262 (700)

### 3.5 Pump capacities

The following table details the pump capacities for the pump models. This figure will change depending upon speed, pressure, temperature and product being pumped.

Pump model	Maximum speed rpm	Maximum capacity at max speed m <sup>3</sup> /hr (US gpm)
DD50	1440	11.0 (48)
DD75 PS	750	25.0 (110)
DD100 PS	750	35 - 40 (154 - 176)

## Operating Manuals

### **4.0 System design and installation**

#### **4.1 System design advice**

When designing the pumping system :-

- Do** - confirm with the supplier the Net Positive Suction Head (NPSH) requirements for the system, as this is crucial for ensuring the smooth operation of the pump and preventing cavitation.
  - Do** - protect the pump against blockage from hard solid objects e.g. nuts, bolts etc. Also protect the pump from accidental operation against a closed valve by using one of the following methods :- relief valves, pressure switch, current monitoring device.
  - Do** - fit suction and discharge pressure gauges to monitor pressures for diagnostic purposes.
  - Do** - install non-return valve to prevent syphoning when high pressures are applied to the pump whilst it is not in use. Valves are also recommended if two pumps are to be used on manifold/common discharge lines.
- Do** - provide a hose cleaning facility to assist maintenance, ensuring the drive unit meets the specification for hose cleaning.

## 4.2 Pump and base foundations

Depending on your requirements the pump and drive (if supplied) may arrive mounted on a baseplate. Our standard baseplates have pre-drilled fixing holes to accept base retaining bolts.

To provide a permanent, rigid support for securing the pump unit a foundation is required, this will also absorb vibration, strain or shock on the pumping unit.

### Foundation size

The foundation should be approximately 6 inches longer and wider than the mounting base of the unit. The depth of the foundation should be at least 20 times the diameter of the foundation bolts.

### Bolt location dimensions

The location and sizes of the relevant bolting down holes can be provided on a certified drawing from your supplier.

### Typical foundation bolts

The drawing below shows two methods for foundation bolt retaining. The sleeve allows for 'slight' lateral movement of the bolts after the foundation is poured. Use rag or paper to prevent the concrete from entering the sleeve while the foundation is poured. A minimum of 14 days is required to allow the curing of the concrete prior to operation.

D = Diameter of foundation bolts

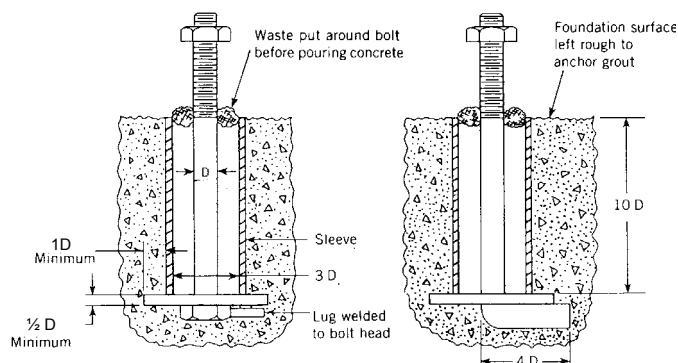

## 4.3 Installation

Before the pump is installed it is advisable to consider the following:

- Always -** ensure that the mounting surface is flat to avoid distortion of the baseplate. This will cause pump/motor shaft misalignment and pump/motor unit damage.
- Check -** **pump shaft to motor shaft alignment** once the baseplate has been secured and adjust as necessary.
- Allow -** at least one metre (three feet) for pump access/maintenance all around the pump.
- Weight -** Consider the weight of the pump, drive and lifting gear requirements.
- Electrical - supply** Ensure that there is an adequate electrical supply close to the pump drive unit. This should be compatible with the electric motor selected.

## Operating Manuals

### 4.4.1 Coupling alignment (metric)

When installing the pump and drive unit, it is **essential** to ensure that the coupling is **not misaligned** during installation. The main cause of misalignment is by fitting the baseplate to an uneven surface.

Check the maximum angular and parallel allowable misalignments for the couplings before operating the pump.

#### Parallel misalignment

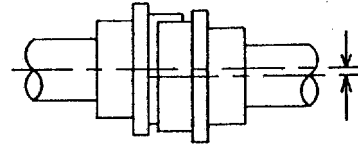

#### Angular misalignment

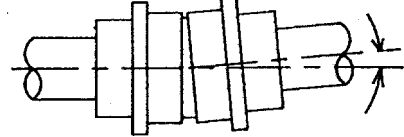

Coupling type	Maximum parallel misalignment		Maximum angular misalignment
	Size	mm	Degrees
David Brown Nylicon Flexible	1	0.2	± 1.5° (PER GEAR IN MESH)
	2	0.3	
	3	0.4	
William Kenyon Flexilok	FL63	0.25	0.75°
	FL80		
	FL112	0.3	1.0°
	FL125	0.4	
	FL160	0.5	
Fenaflex Flexible Tyres	F40	1.1	4°
	F50	1.3	
	F60	1.6	
	F70	1.9	
	F80	2.1	
	F90	2.4	

**Note :** The above table indicates the common coupling types used on the pump ranges.  
Details for other coupling types will be available on request.

4.4.2 Coupling alignment (imperial)

When installing the pump and drive unit, it is **essential** to ensure that the coupling is **not misaligned** during installation. The main cause of misalignment is by fitting the baseplate to an uneven surface.

Check the maximum angular and parallel allowable misalignments for the couplings before operating the pump.

Parallel misalignment

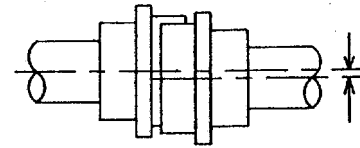

Angular misalignment

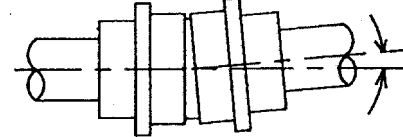

Coupling type	Size	Maximum parallel misalignment	Maximum angular misalignment
		Inches	Degrees
T. B. WOODS SURE - FLEX EPDM SLEEVE	5	.015"	.056"
	6	.015"	.070"
	7	.020"	.081"
	8	.020"	.094"
	9	.025"	.109"
	10	.025"	.128"
T. B. WOODS SURE - FLEX HYTREL SLEEVE	5	---	---
	6	.010"	.016"
	7	.012"	.020"
	8	.015"	.025"
	9	.017"	.028"
	10	.020"	.032"

**Note :** The above table indicates the common coupling types used on the pump ranges. Details for other coupling types will be available on request.

# Operating Manuals

## 4.5.1 Pulley belt tension adjustment (metric)

An incorrectly tensioned belt will cause belt slip and short belt life. **An excessively tensioned belt will overload both belts and bearings. Always use a belt tension gauge for setting up.**

**Isolate** the drive unit and pump from all power and control supplies before attempting to work on adjusting the belts.

1. Measure the span length.
  2. Calculate the required deflection: ('x')
- 100mm span length = 1mm deflection
- therefore :
- 400mm span length = 4mm deflection
3. Refer to the table for recommended minimum and maximum deflection force for small pulley diameter range.

To convert Newtons to **pounds force** multiply by 0.2248.

To convert Newtons to **kilogrammes force** multiply by 0.1020.

4. Use a belt tension gauge with the figures to determine the belt adjustment required.
5. Belt tension adjustment is achieved by adjusting the nuts on the pedestal frame.
6. Finally check that all nuts are re-tightened and the belts can move 'freely' by hand (depending upon pump size and system

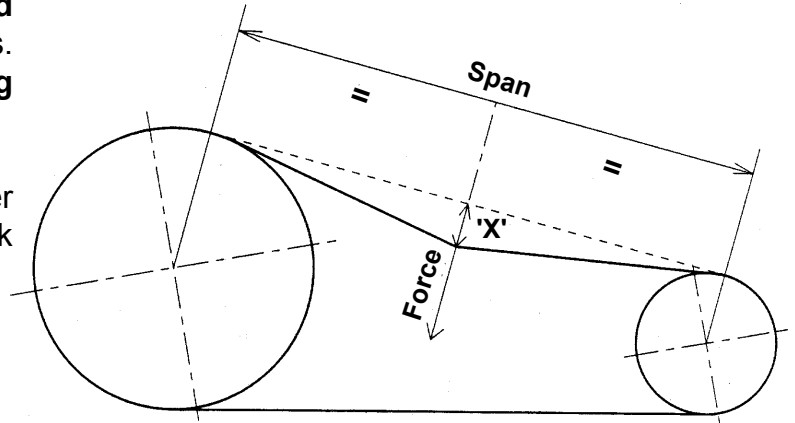

**'X' = 1 mm deflection per 64 mm of span**

**Important :** When adjusting the belt tension the four bolts that hold the motor support collars to the adjusting rails must only be slackened just enough to allow movement. (approx 1/4 turn). The belt tension can then be adjusted by tightening and loosening the appropriate adjusting screws to achieve the correct tension and pulley alignment.

Belt section	Small pulley diameter Range	Recommended deflection force Newtons	
	MM	Min	Max
XPZ SPZ	56	7	11
	60-63	8	13
	67-71	9	14
	75-80	10	15
	85-95	11	16
	100-125	13	19
XPA SPA	132-180	16	24
	80-125	18	27
	132-200	22	31

**Note :** The above table indicates the common pulley types used on the pump ranges. Details for other pulley types will be available on request.

**4.5.2 Pulley belt tension adjustment (imperial)**

An **incorrectly tensioned belt** will cause belt slip and short belt life. An **excessively tensioned belt** will overload both belts and bearings. ALWAYS USE A BELT TENSION GAUGE FOR SETTING UP.

**ISOLATE** the drive unit and pump from all power and control supplies before attempting to work on adjusting the belts.

1. Measure the span length.
2. Calculate the required deflection: ('x')

3.94" span length = 0.04" deflection

therefore :

15.75" span length = 0.16" deflection

3. Refer to the table for recommended minimum and maximum deflection force for small pulley diameter range.
4. Use a belt tension gauge with the figures to determine the belt adjustment required.
5. Belt tension adjustment is achieved by adjusting the nuts on the pedestal frame.
6. Finally check that all nuts are re-tightened and the belts can move 'freely' by hand (depending upon pump size and system design).

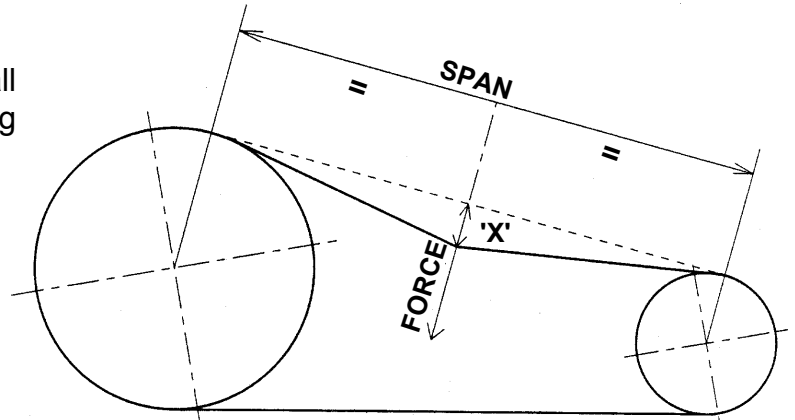

**'X' = 1/64 " Deflection per one inch of span**

**Important :** When adjusting the belt tension the four bolts that hold the motor support collars to the adjusting rails must only be slackened just enough to allow movement. (approx 1/4 turn). The belt tension can then be adjusted by tightening and loosening the appropriate adjusting screws to achieve the correct tension and pulley alignment.

Recommended minimum force per belt						
	Small sheave		Drive ratio			
	Speed Range	Dia.	1.0	1.5	2.0	4.0 & over
3VX	1200-3600	2.20	2.2	2.5	2.7	3.0
	1200-3600	2.50	2.6	2.9	3.1	3.6
	1200-3600	3.00	3.1	3.5	3.7	4.2
	1200-3600	4.12	3.9	4.3	4.5	5.1
	1200-3600	5.30	4.6	4.9	5.1	5.7
	1200-3600	6.9	5.0	5.4	5.6	6.2
5VX	1200-3600	4.4	6.5	7.6	8.0	9.0
	1200-3600	5.2	8.0	9.0	9.5	10
	1200-3600	6.3	9.5	10	11	12
	1200-3600	7.1	10	11	12	13
	900-1800	9.0	12	13	14	15
	900-1800	14.0	14	15	16	17
BX	1200-1800	4.6	5.2	5.8	6.0	6.9
	1200-1800	5.0	5.4	6.0	6.3	7.1
	1200-1800	6.0	6.0	6.4	6.7	7.1
	1200-1800	8.0	6.6	7.1	7.5	8.2

**Maximum deflection force = Minimum times 1.5 common pulley types used on the pump ranges. Details for other pulley types will be available on request.**

## Operating Manuals

### 4.6 Pipework

All pipework **must** be supported. The pump **must not** be allowed to support any of the pipework weight.

**Remember -** Pipework supports must also support the weight of the product being pumped.

#### **Always :-**

**Have -** Short straight suction lines to reduce friction losses in the pipework thereby improving the NPSH available.

**Avoid -** Bends, tees and any restraints close to either suction or discharge side of pump. Use long radius bends wherever possible.

**Provide -** Isolating valves on each side of the pump to isolate the pump when necessary.

**Keep -** Pipework horizontal where applicable to reduce air locks. Include eccentric reducers on suction lines.

**Check -** Coupling alignment during installation to highlight pipework alignment/support problems.

## 4.7 Recommended layout for suction lift

To improve the pump's suction performance it is advisable to install the pump as shown in (A). It is essential that the pumping system incorporates a discharge head of approximately 0.5 m (2 feet) minimum.

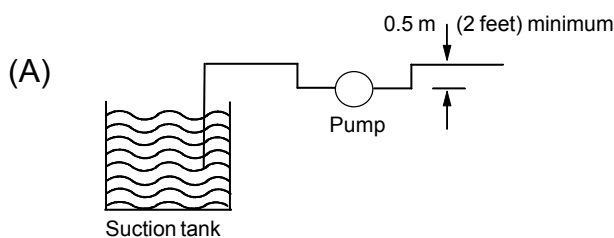

If the discharge outlet is positioned lower than the suction inlet, a 19.05 mm ( $\frac{3}{4}$ " ) diameter non return valve should be fitted to the pipework system as shown in (B).

This will prevent a siphoning effect occurring when the pump is not operating.

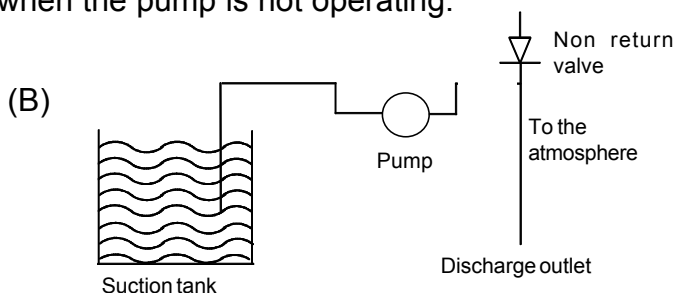

It is not recommended to set the pumping system up as in (C) as there is no forward barrier to flow. The discharge pipework must rise above the suction tank level as shown in (D) to prevent a siphoning effect.

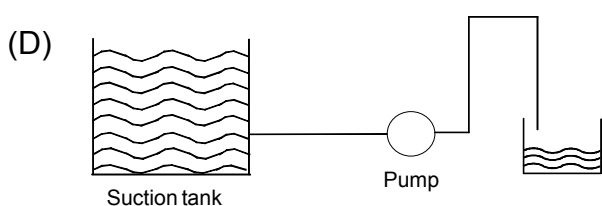
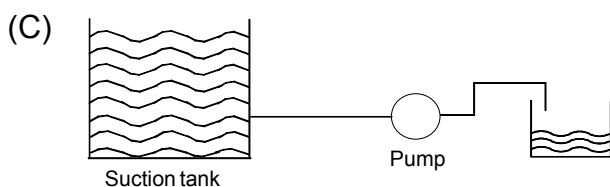

## 4.8 Pulsation

The dual diaphragm pump is a reciprocating pump and produces a pulsing flow. In some installations this can cause vibration and noise in pipework so it is essential that the following precautions are taken :

1. All pipework and fittings must be adequately supported and all fastenings correctly aligned and secure.
2. All fastenings should be checked during commissioning and at regular intervals during operation.
3. Avoid use of short radius bends, elbows and tees.
4. Pulsation dampers should be considered for pumps operating above 1.5 bar (21 psi) and/or delivering through long pipe runs. Lightweight PVC or polythene pipe is more prone to vibration than cast iron or steel.

Pulsation dampers should be selected for specific duty conditions, although it is possible to use simple surge chambers in some situations. For further advice on pulsation problems contact the supplier.

# Operating Manuals

## 5.0 Commissioning

---

### 5.1 Lubrication

#### Ancillaries :-

If a gearbox is fitted, check lubrication against manufacturers instructions supplied with each assembled unit. This applies to all ancillary equipment such as internal combustion engines.

When engines or geared motors are fitted, the gearbox should be filled with the correct grade and quantity of oil before starting up. Although some types of gearbox are supplied with oil it is always advisable to check the oil level first.

#### Recommended grease

The following details the recommended grades of grease.

Make	Specification
MOBIL	MOBILUX EP3
SHELL	CALITHIA EPT2
ESSO	UNIREX EP2 BEACON EP2

#### Pump drive shaft :-

The main drive shaft bearings are fitted with grease nipples, and require periodic greasing. It is advised that the following should be used as a guide.

- Hardworking conditions / continual use every 3 months.
- Average working conditions - every 6 months.
- Periodic/occasional use - once a year.

## 6.0 Start up, shut down and cleaning in place

---

6.1 Pump start-up check list	<b>Yes</b>	<b>No</b>
1. Is the location of the <b>'stop'</b> button clear?	<input type="checkbox"/>	<input type="checkbox"/>
2. Has the pipework system been flushed through to purge welding slag and any other hard solids?	<input type="checkbox"/>	<input type="checkbox"/>
3. Have all <b>obstructions</b> been removed from the pipework or pump?	<input type="checkbox"/>	<input type="checkbox"/>
4. Are the pump <b>connections</b> and pipework joints <b>tight</b> and <b>leak-free</b> ?	<input type="checkbox"/>	<input type="checkbox"/>
5. Is there <b>lubrication</b> in the <b>pump</b> and <b>drive</b> unit?	<input type="checkbox"/>	<input type="checkbox"/>
6. Has the pump been <b>primed</b> ? If not see priming section.	<input type="checkbox"/>	<input type="checkbox"/>
7. Are the pipework <b>valves open</b> ?	<input type="checkbox"/>	<input type="checkbox"/>
8. Are <b>all safety guards</b> in place?	<input type="checkbox"/>	<input type="checkbox"/>
9. Start then stop the pump, is the product <b>flowing</b> in the correct <b>direction</b> ?	<input type="checkbox"/>	<input type="checkbox"/>
10. Are the pump <b>speed/pressure</b> settings below the pump maximum limitations?	<input type="checkbox"/>	<input type="checkbox"/>

All answers should be 'yes' before proceeding.

If there are any pumping problems refer to the fault finding chart.

## Operating Manuals

### 6.2 Priming the pump

Priming is where the pumps chambers are wetted to accelerate pumping. The dual disc pump will establish a prime over a period of time, dependent upon the speed it is running and the product being pumped. Priming time will be reduced by pre-filling the pumping chambers with water through the plugged priming inlets provided. These are located in the intermediate housing on the DD50 and at the neck of the discharge housing on the DD75 PS and DD100 PS pump units.

Optimum performance will be achieved by running the pump at 300-350 rpm.

Suction piping and all joints must be air-tight for reliable priming to take place. Suction performance can be checked using a vacuum gauge. This should be mounted in the suction piping close to the duty conditions. Any significant drop in the vacuum gauge reading, will indicate possible air leaks.

### 6.3 Pump shut down procedure

1. Turn the pump off.
2. Isolate the pump/drive unit from all power and control supplies.
3. Close the pipework valves to isolate the pump.
4. If the pump is to be dismantled refer to the dismantling section.

## 7.0 Maintenance and inspection

### 7.1 Maintenance schedule

It is advisable to install pressure gauges either side of pump so that any problems within the pump/pipework will be highlighted.

#### Your weekly schedule should include:

- Checking if the pump has any signs of leakage.
- Checking pumping pressures.

### 7.2 Recommended spares

The following spare parts should be held on site at all times and it is recommended that the disc's, trunnions and check valve be changed at approximately yearly intervals depending on the severity of the pump duty. The part numbers are shown below:

Description	Qty	DD50		DD75 PS		DD100 PS	
		Item No	Part No	Item No	Part No	Item no	Part no
Trunnion	2	33	7-700213	20	7-730020	19	7.730021
Discharge (flow) disc	1	39	7-700220	25	7-700350	21	7.740351
Suction (lift) disc	1	40	7-700219	26	7-700351	20	7.740350
Check Valve	1	43	7-700224	29	7-700326	22	7.740326
Disc Retainer Nut	2	42	7-700002	28	7-700006		N/A
Gasket - Suction	1	46	7-700227	31	*7-730025	27	*7.730024
Gasket - Discharge	1	45	7-700228	30	*7-730024	26	*7.730025

\* - EPDM only

## Operating Manuals

### 8.0 Disassembly

---

#### 8.1 Before dismantling the pump

Before starting to dismantle the pump  
**always:-**



**Purge -**

the pump and system if any noxious products have been pumped.



**Isolate -**

pump/drive unit from all power and control supplies.



**Close -**

pipework valves to isolate the pump



**Disconnect -**

the pump from the drive unit.

**Read this section first before  
continuing to dismantle the pump.**

The following section describes the dismantling and assembly of the pump to allow inspection and/or replacement of the housing, trunnions, disc's and gaskets. It is assumed that the drive shaft assembly will be removed and replaced as a single assembly. If for some reason the drive shaft assembly does require attention, a section for dismantling and assembly has been included.

### 8.2 Dismantling the DD50 dual disc pump

For dismantling purposes it is best to remove the pump completely from the frame. For all numbered items refer to the exploded pump drawing and parts list.

1. Unscrew the drain plug (59) and completely drain the pump out.
2. Dismantle the drive cover and disconnect the drive couplings.
3. Turn the pump upside down.
4. Remove the 10 housing retainer bolts (53, 55, 56) nuts and washers (54, 48, 49) and separate the suction housing (4) along with the suction gasket (46).
5. Remove the two disc retainer plate nuts (42) from the drive rod ends (25, 26) and the two diaphragm retainer plates (41) followed by the suction disc (40).
6. The discharge disc (39) should be carefully removed by pulling it through the intermediate housing (3). Untighten and remove the discharge spacer nut (38), so that both disc retaining plates (37) and 'O' rings (36) can be removed. Remove the trunnion holders (29, 32).
7. Turn the pump the right way up.
8. The drive assembly is bolted to the discharge housing by the discharge and suction pedestal bolts (47, 50). Remove the bolts and lift off the drive assembly.
9. The trunnion holders (28, 31) and drive rod sleeve (27) are loose and will slide off the drive rods.
10. The discharge trunnion (33) is held in place by a trunnion clamp ring (30), followed by a trunnion clamp ring retention bolt (51). The trunnion is released by removing the bolt.
11. The discharge (2) and intermediate housing (3) can now be separated, and the suction trunnion clamp ring (30) and trunnion (33) removed.
12. Access to the check valve (43) is gained by simply removing the 3 bolts (57) and taking off the swan neck (5).
13. Now that the pump has been dismantled it is advisable to inspect and replace the suction and discharge gaskets, discs and trunnions where necessary.

## Operating Manuals

### 8.3 Dismantling the DD50 dual disc pump drive shaft assembly

**NOTE : DO NOT** dismantle the drive assembly, unless components within the assembly require replacements, otherwise re-setting will be necessary.

If dismantling of the drive assembly is required, careful attention to the DD50 dual disc exploded pump drawing will aid removal of parts.

1. The dust caps (17, 18) positioned at either end of the drive shaft should be removed by untightening the nuts (22).
2. The pedestal bearings (14) can be released by untightening the grub screws which locate on the drive shaft (6). The pedestals (1) can now be removed from the shaft.
3. Remove the circlips (9) from the con rods, (24) which retain the con rod bearings (7), and untighten the bearing retainer bolts.

4. The cam lobes (8) are located to the shaft by a drive pin and have been pressed into the con rod bearings (7), so a suitable press will be required to aid removal if necessary, whilst the cam lobe remains on the shaft.
5. Each cam lobe is retained on the drive shaft by a drive pin (10), which can be removed by using a smaller diameter pin and tapping the existing one through.

With the drive assembly dismantled each part should be inspected and replaced as necessary. Prior to re-assembling the parts it is advisable to clean them thoroughly and lubricate where required.

### 8.4 Dismantling the DD75 PS dual disc pump from mounting frame

The pump may be either removed completely from the frame, or dismantled in situ, leaving the intermediate housing (31) in position.

#### PORTABLE OR OVERHEAD LIFTING TACKLE MUST BE USED

Remove the belt guard and take off the pulley from the pump shaft and remove the belts. The pulley is generally fixed to the pump shaft with "Taperlock" bushes. These are removed as follows:

1. Using a hexagon wrench slacken all screws by several turns, remove the same number as there are 'jacking off' holes, these will be used to jack off the bush.
2. The jacking off screws should then be oiled on the threading point of grub screws or along the thread and under surface of head in cap screws.
3. Insert the 'jacking off' screws in the jacking off holes, and tighten them alternately until bush is loosened in the hub of the pulley and is free as the shaft.
4. The assembly can now be removed from the shaft.
5. Remove the bolts fixing the pump to the frame and lift the pump clear.

⊙ JACKING IN SCREW

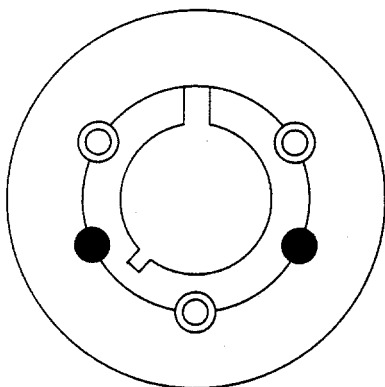

● JACKING OFF HOLE

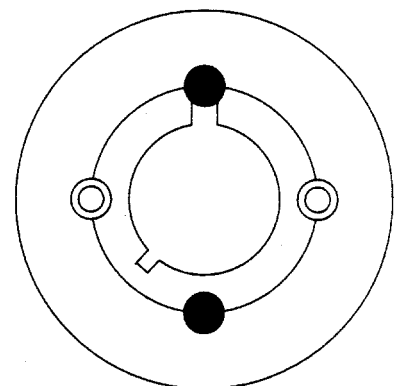

## Operating Manuals

### 8.5 Dismantling the DD75 PS dual disc pump

For dismantling purposes it is best to remove the pump completely from the frame and continue with the pump lying on its side, or supported upside down.

1. Unscrew the drain plug and completely drain the pump out.
2. Dismantle the drive cover and disconnect the drive couplings.
3. Turn the pump on its side or upside down.
4. The suction housing (4) can be removed by undoing the 6 bolts (41) and 4 nuts (36) on the end of the studs (35).
5. Remove the 2 self locking nuts (28) from the suction and discharge drive rod ends (17, 18).
6. On the suction side, remove the disc retainer plate (23, 27), and suction disc (26).
7. Remove the intermediate housing (3) by undoing the 4 bolts and nuts (37, 40).
8. Access has now been gained so that the discharge disc retainer plates (23, 27), discharge disc(25), suction and discharge spacer nuts (24), and the top dis cretainer plates (23,27), can be removed.
9. Remove the two clamp collars (21, 22) along with the suction trunnion (20) and suction clamp ring (16).
10. The drive assembly is bolted to the discharge housing (2) by 4 bolts (32), which when removed, allow separation of the drive assembly from the discharge housing.
11. The discharge clamp ring (15) and discharge trunnion (20) can now be removed.
12. The check valve can be examined by removing the 4 bolts (41) and taking off the swan neck.
13. Now that the pump has been dismantled it is advisable to inspect and replace the suction and discharge gaskets, disc's and trunnions, where necessary.

### 8.6 Dismantling the DD75 PS dual disc pump drive shaft assembly

**NOTE :** Do not dismantle the drive assembly unless components within the assembly require replacement, otherwise re-setting will be necessary.

If dismantling of the drive assembly is required, careful attention to the 3" dual disc exploded pump drawing will aid removal of parts.

1. The bearing block bolts (44) should be removed to allow separation of the drive assembly from the drive frame.
2. Untighten the bearing block grub screws and remove the two bearing blocks positioned at either end of the shaft.
3. The cam lobes are keyed to the shaft and each is secured by two grub screws. Slacken the grub screws (11) from the cam lobes (8), and remove the cam lobe circlips (9).
4. A suitable press is required to aid removal of the cam lobes (8) from the centre of the con rod bearings (7).
5. The con rod bearings (7) may be released by removing the bearing retainer bolts (47), and pushing the bearings out with a suitable press.

With the drive assembly dismantled each part should be inspected and replaced as necessary. Prior to re-assembling the parts it is advisable to clean them thoroughly and lubricate where required.

## Operating Manuals

### 8.7 Dismantling the DD100 PS pump from mounting frame

The pump may be either removed completely from the frame, or dismantled in situ, leaving the intermediate housing (31) in position.

**Portable or overhead lifting tackle must be used.**

Remove the belt guard and take off the pulley from the pump shaft and remove the belts. The pulley is generally fixed to the pump shaft with "Taperlock" bushes. These are removed as follows:

1. Using a hexagon wrench slacken all the screws by several turns, remove the same number as there are 'jacking off' holes, these will be used to jack off the bush.
2. The jacking off screws should then be oiled on the threading point of grub screws or along the thread and under surface of head in cap screws.

3. Insert the 'jacking off' screws in the jacking off holes, and tighten them alternately until bush is loosened in the hub of the pulley and is free as the shaft.
4. The assembly can now be removed from the shaft.
5. Remove the bolts fixing the pump to the frame and lift the pump clear.

⊙ Jacking in screw

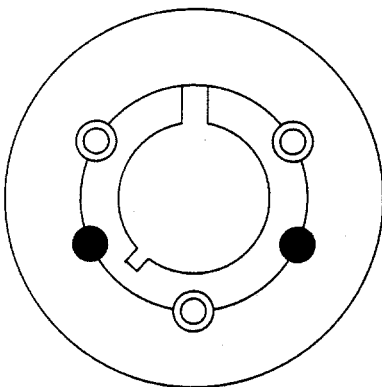

● Jacking off hole

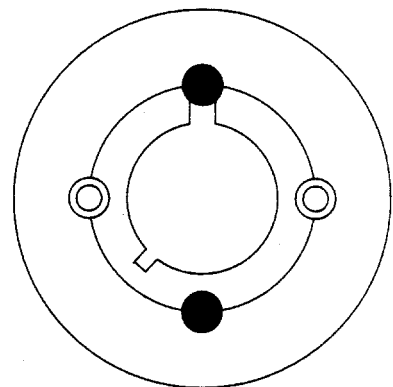

### 8.8 Dismantling the DD100 PS pump

For dismantling purposes it is best to remove the pump completely from the frame and continue with the pump lying on its side, or supported upside down.

1. Unscrew the drain plug and completely drain the pump out.
2. Dismantle the drive cover and disconnect the drive couplings.
3. Turn the pump on its side or upside down.
4. The suction housing (4) can be removed by undoing the 5 bolts (37) and 4 nuts (32) on the end of the studs (31).
5. On the suction side, remove the suction disc (20).
6. Remove the intermediate housing (3) by undoing the 4 bolts and nuts (33, 36).
7. Access has now been gained so that the discharge disc (21) can also be removed.
8. Remove the suction trunnion (19) and suction clamp ring (16).
9. The drive assembly is bolted to the discharge housing (2) by 4 bolts (28), which when removed, allow separation of the drive assembly from the discharge housing.
10. The discharge clamp ring (15) and discharge trunnion (19) can now be removed.
11. The check valve can be examined by removing the 4 bolts (37) and taking off the swan neck.
12. Now that the pump has been dismantled it is advisable to inspect and replace the suction and discharge gaskets, disc's and trunnions, where necessary.

## Operating Manuals

### 8.9 Dismantling the DD100 PS pump drive shaft assembly

**Note :** Do not dismantle the drive assembly, unless components within the assembly require replacements, otherwise re-setting will be necessary.

If dismantling of the drive assembly is required, careful attention to the DD100 PS dual disc exploded pump drawing will aid removal of parts.

1. The bearing block bolts (40) should be removed to allow separation of the drive assembly from the drive frame.
2. Untighten the bearing block grub screws and remove the two bearing blocks positioned at either end of the shaft.
3. The cam lobes are keyed to the shaft and each is secured by two grub screws. Slacken the grub screws (11) from the cam lobes (8), and remove the cam lobe circlips (9).

4. A suitable press is required to aid removal of the cam lobes (8) from the centre of the con rod bearings (7).
5. The con rod bearings (7) may be released by removing the bearing retainer bolts (43), and pushing the bearings out with a suitable press.

With the drive assembly dismantled each part should be inspected and replaced as necessary. Prior to re-assembling the parts it is advisable to clean them thoroughly and lubricate where required.

## 9.0 Assembly

### 9.1 Assembly of the DD50 dual disc pump drive shaft assembly

1. Screw the suction (26) and discharge (25) drive rods into the con rods (24).
2. Press the bearings (7) into the suction and discharge con rods (24), and retain using the circlips (9).
3. Slide the cam lobes (8) onto the drive shaft (6) and insert the pins (10) into the thinner side of the cam lobes through into the holes in the drive shaft. NOTE ; The cams must be 180° in opposition to one another.
4. Pass the con rod and bearing assembly over the shaft, and using a suitable press, push the cam lobes into the drive rod bearings (7), making sure they go right in and align correctly.
5. Locate and tighten the bearing retaining bolt (11) with washers (12,13) into the con rods (24).
6. Put the bearings (14) in between the two metal plates (15) and using the bolts (20) tighten the bearings against the pedestals (1).
7. Mount the pedestals on each end of the shaft, refer to exploded pump drawings for orientation.
8. The distance between the pedestals and con rods is important and must be set up as shown.
9. Once the correct measurement has been attained, the shaft bearing grub screws should be removed and the shaft dimpled through the holes to mark the correct position. Then replace and re-tighten the grub screws.
10. Place the felt gasket (16) over the non drive end of the shaft followed by the nut (22) and the dust cap (17). Another nut (22) along with a washer (23) is used to retain the dust cap.
11. Grease the key end of the drive shaft (6) and place the felt gasket (16) over the shaft. Tighten the nut (22) which locates within the gasket. Push the smaller felt gasket (19) into the cone of the dust cap (18). Use another nut and washer (23) to retain the dust cap.
12. Finally, check that the pedestals spin on the shaft smoothly.

**NOTE :** These bearings have grub screws to retain them on the shaft. Ensure that the end of the bearings nearest the grub screws point towards the drive end of the shaft.

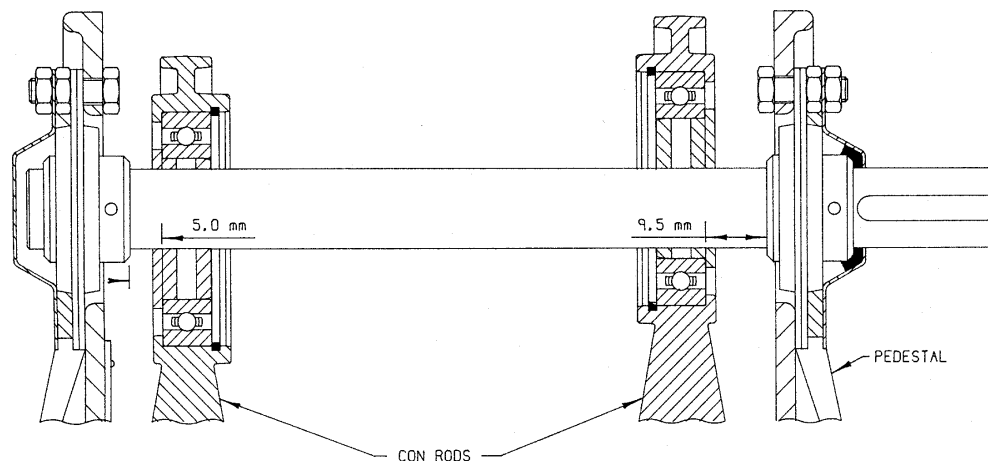

## Operating Manuals

### 9.2 Assembly of the DD50 dual disc pump

It is advisable to study the exploded disc parts list of the DD50 dual disc pump before commencing the assembly procedure.

**NOTE :** New gaskets should always be fitted when reassembling the pump.

1. Ensure that the discharge housing (2) gasket face is thoroughly cleaned. Apply a suitable adhesive to the discharge housing face and carefully align the discharge gasket (45) onto it. Depending on the adhesive type allow a period of time for the adhesive to dry.
2. Starting with the intermediate housing (3) the right way up. Lightly grease the trunnion (33) and place it in the suction side of the housing. Push the clamp ring in so that it sits on top of the trunnion.
3. Using suitable bolts and washers temporarily bolt the discharge housing to the intermediate housing. Insert the remaining trunnion (33) and clamp ring (30) into the discharge side of the discharge housing.
4. Tighten down clamp ring retainer bolt (51) with washers (48, 52) see page 37 for torque values.
5. Push the discharge trunnion holder (28) onto the discharge drive rod (25) and the drive rod sleeve (27) followed by the suction trunnion holder (31) onto the suction drive rod (26).  
**NOTE :** Long holder on discharge drive rod, short holder on suction drive rod.
6. Mount the drive assembly on the top of the discharge housing using the 4 bolts (2 off 47, 2 off 50) and washers (48, 49). Carefully insert the drive rods 25, 26 through both trunnions (33). Tighten down the bolts.
7. Rotate the drive shaft, so the discharge drive rod (25) is in its maximum upper position of the pumping cycle.
8. Turn the pump upside down.
9. Push the remaining discharge trunnion holder (29) onto the discharge drive rod (25) and the suction trunnion holder (32) onto the suction drive rod (26).  
**NOTE :** Long holder on suction, short holder on discharge drive rod (opposite to as before).
10. Locate one 'O' ring (36) on each of the drive rods up against the trunnion holders.
11. Place the small disc retainer plates (37) over the suction and discharge drive rods and tighten the disc spacer nuts (38).
12. Insert the discharge disc (39) over the discharge drive rod and into the intermediate housing and carefully bend the disc. Place the suction disc (40) over the suction drive rod.
13. Place both large disc retainer plates (41) followed by the disc retaining nuts (42) over each of the drive rods. Tighten down to torque values detailed on page 37.  
**NOTE :** Ensure disc spins as this will greatly assist the transfer of any stones etc, should they enter the pump.
14. Clean the suction housing (4) gasket face and apply a suitable adhesive to the surface. Centralise the suction gasket (46) onto the suction housing and allow to dry.

### 9.2 Assembly of the DD50 dual disc pump (continued)

15. Ensure draining plug (59) is tightened to the recommended torque see page 37.
16. Place the suction housing onto the intermediate housing and bolt the housings together along with the discharge housing using bolts (53, 55, 56), washers (48, 49) and nuts (54). Working diagonally, to ensure an even spread, see page 37 for torque values.  
**NOTE** : Systematically remove the temporary nuts and bolts which held the discharge housing to the intermediate housing, and replace with the correct nuts and bolts detailed above.
17. Before bolting on the swan neck (5), ensure that the three spacers (44) are pushed into the holes in the check valve (43). See the torque values page 37 before tightening the bolts (57). Make sure the hole has no sharp edges.
18. Re-tighten all nuts and bolts see page 37 for torque values.

## Operating Manuals

### 9.3 Assembly of the DD75 PS dual disc pump drive shaft assembly

1. Screw both suction (18) and discharge (17) drive rods into both the suction (14) and discharge (13) con rods, press the con rod bearings (7) into each con rod and locate pin (60).  
**NOTE :** The suction drive rod has a machined identification groove.
2. Fit a circlip (9) onto each of the cam lobes (8) and push the cam lobes into each con rod, using a suitable press. Fit the remaining circlips (9) into the remaining recess of the cam lobes.
3. The bearings may now be retained using the screws, washers and bearing retainers (47, 48, 49).
4. Fit one of the keys (10) in the shaft keyway furthest from the drive end, and slide the discharge con rod (13) onto the shaft with the bearing retainer facing inwards.
5. Assemble middle bearing blocks (12) onto the slightly raised portion of the shaft, located roughly in the middle.
6. Fit the remaining key (10) on the shaft and slide the suction con rod onto the shaft locating the cam lobe (8) over the key, with the bearing retainer facing upwards.
7. Both end bearing blocks (12) can now be put onto the shaft ensuring that the grub screws face the keyway end of the shaft. Lightly tap the bearings with a soft mallet making sure they align properly. The shaft end without the keyway should only be allowed to protrude 3mm from the bearing.
8. Tighten down the 6 bolts, spring washer and washers (44, 39, 38) onto the drive support frame (1).
9. Slacken off the grub screws (11) and adjust the distance from the central web to the con rod bearings, to 82.8mm (3.260") as shown in Fig 5. Re-tighten the grub screws.

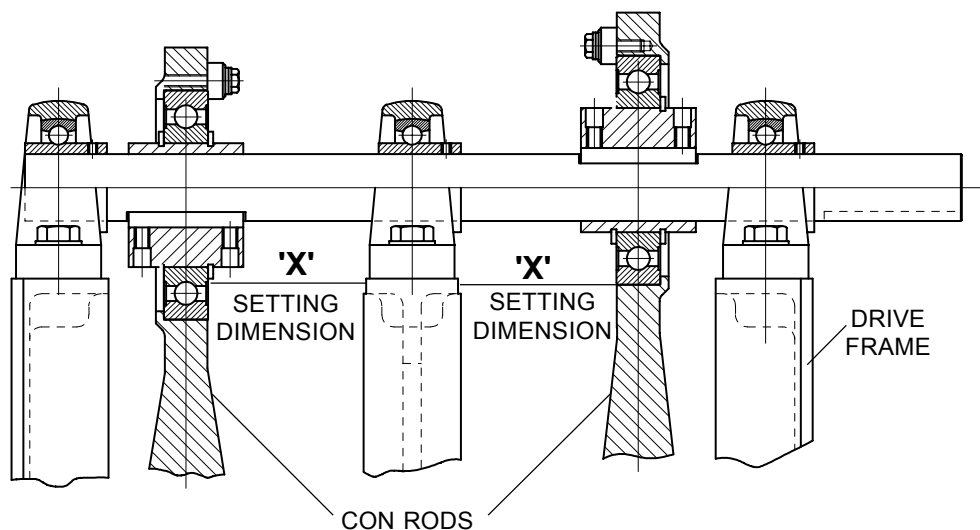

Dimension 'X' = 82.8 ± 0.15 mm  
(3.26 ± 0.01 inches)

### 9.4 Assembly of the DD75 PS dual disc pump

**NOTE :** New gaskets should always be fitted when the pump is re-assembled.

1. Thoroughly clean the discharge housing (2) and suction housing (4) gasket faces. Apply a suitable adhesive to the faces, and carefully align the discharge gasket (30), and suction gasket, (31) onto their respective faces. Depending upon the adhesive type allow a period of time for the adhesive to dry.
2. Support the drive assembly either on its side or preferably in the upside down position.
3. Lightly grease one of the trunnions (20) and place in onto the discharge drive rod of the drive assembly (2); follow with the discharge clamp ring (15).
4. Using the small location pin (19) on the underside of the drive frame, place the discharge housing (2) onto the drive assembly, locating the trunnion and clamp ring in the discharge bore.  
**NOTE :** The discharge housing should be positioned, such that the flange of the housing is at the opposite end to the keyway on the drive shaft (6).
5. Fit and tighten the screws (32) with the washers and spring washers (33, 34), but not to the final torque value.
6. With the discharge housing (2) inverted, insert the suction clamp ring (16) over the suction drive rod, and into the suction bore of the discharge housing, followed with the remaining trunnion (20).
7. With the radiused end downwards, place the clamp collars (shortest length collar discharge (21), longest length collar suction (22) ) and disc retainer plates (23) over the suction (18) and discharge (17) drive rods. The disc retainer nuts (24) should now be tightened down to the torque value specified.
8. The discharge disc (25) (the smaller pumping disc) should be fitted over the discharge drive rod (17). Note that the bevelled edge should be pointing down towards the discharge housing (2).
9. The intermediate housing (3) with the 4 studs can now be located onto the discharge housing (2) and the washers (35) spring washers (39) and nuts (36) tightened to torque values.
10. Place the suction disc (26) over the suction drive rod (18).  
**NOTE :** That the bevelled edge should be pointing towards the intermediate housing (3).
11. Fit both disc retainer plates (27), with the bevelled edge upwards and tighten down the disc retainer nuts (28) see page 37 for torque values.  
**NOTE :** Ensure that the suction disc (26) is free to rotate as this will assist the transfer of any stones etc, should they enter the pump.
12. Carefully mount the suction housing (4) onto the intermediate housing (3) and insert the bolts and washers (38, 39 41) into their respective places. They should now be tightened to the required torque value.
13. Place the check valve (29) in between the suction housing (4), and swan neck (5). Then progressively tighten the bolts (41) to the required torque value.
14. Replace drain plug.

## Operating Manuals

### 9.5 Assembly of the DD75 PS dual disc pump and drive on frame

Position the assembled pump back on its frame and re-fit the mounting nuts and bolts. Place the pulley and belts back into position and refit the Taper Lock Bush as follows :

1. Sparingly oil thread and point of grub screws, or thread and under head of cap screws.
2. Clean shaft and fit hub and bush to shaft as one unit and locate in position desired.
3. Using a hexagon wrench tighten screws gradually and alternatively until all are pulled up very tightly. The bush will grip the shaft first and then the hub will be drawn on to the bush.
4. After drive has been running under load for a short time, stop and check tightness of screws.
5. Fill empty holes with grease to exclude dirt.

⊙ JACKING IN SCREW

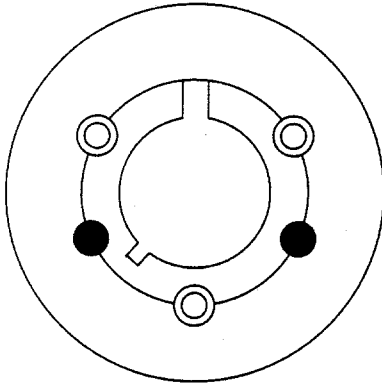

● JACKING OFF HOLE

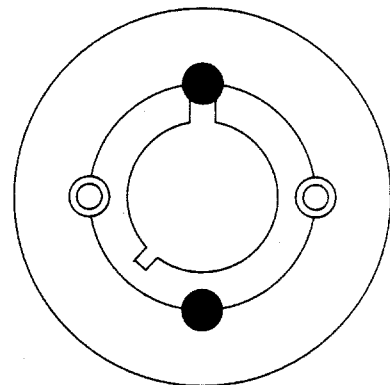

## 9.6 Assembly of the DD100 PS pump drive shaft assembly

1. Screw both suction (18) and discharge (17) drive rods into both the suction (14) and discharge (13) con rods, press the con rod bearings (7) into each con rod and locate pin.  
**Note** : The suction drive rod has a machined identification groove.
2. Fit a circlip (9) onto each of the cam lobes (8) and push the cam lobes into each con rod, using a suitable press. Fit the remaining circlips (9) into the remaining recess of the cam lobes.
3. The bearings may now be retined using the screws, washers and bearing retainers (43, 44, 45).
4. Fit one of the keys (10) in the shaft keyway furthest from the drive end, and slide the discharge con rod (13) onto the shaft with the bearing retainer facing inwards.
5. Assemble middle bearing blocks (12) onto the slightly raised portion of the shaft, located roughly in the middle.
6. Fit the remaining key (10) on the shaft and slide the suction con rod onto the shaft locating the cam lobe (8) over the key, with the bearing retainer facing upwards.
7. Both end bearing blocks (12) can now be put onto the shaft ensuring that the grub screws face the keyway end of the shaft. Lightly tap the bearings with a soft mallet making sure they align properly. The shaft end without the keyway should be allowed to protrude .118" from the bearing.
8. Tighten down the 6 bolts, spring washer and washers (40, 29, 34) onto the drive support frame (1).
9. Slacken off the grub screws (11) and adjust the distance from the central web to the con rod bearings, to the dimensions shown below in Fig 5. Re-tighten the grub screws.

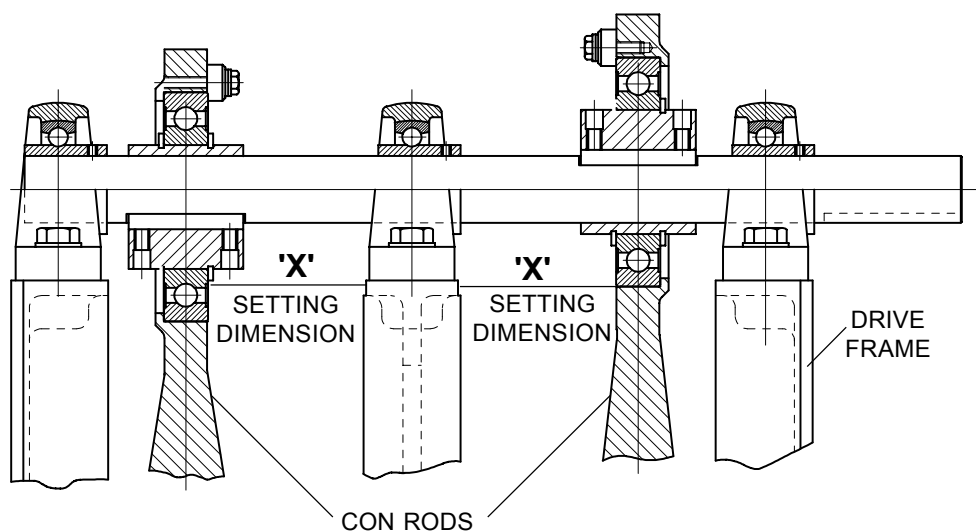

Dimension 'X' =  $82.8 \pm 0.15$  mm  
( $3.26 \pm 0.01$  inches)

## Operating Manuals

### 9.7 Assembly of the DD100 PS dual disc pump

**NOTE :** New gaskets should always be fitted when the pump is re-assembled.

1. Thoroughly clean the discharge housing (2) and suction housing (4) gasket faces. Apply a suitable adhesive to the faces, and carefully align the discharge gasket (26), and suction gasket, (27) onto their respective faces. Depending upon the adhesive type allow a period of time for the adhesive to dry.
2. Support the drive assembly either on its side or preferably in the upside down position.
3. Lightly grease one of the trunnions (19) and place in onto the discharge drive rod of the drive assembly (2); follow with the discharge clamp ring (15).
4. Using the small location pin (18) on the underside of the drive frame, place the discharge housing (2) onto the drive assembly, locating the trunnion and clamp ring in the discharge bore.  
**Note :** The discharge housing should be positioned, such that the flange of the housing is at the opposite end of the keyway on the drive shaft (6).
5. Fit and tighten the screws (28) with the washers and spring washers (29, 30), but not the final torque value.
6. With the discharge housing (2) inverted, insert the suction clamp ring (16) over the suction drive rod, and into the suction bore of the discharge housing, followed with the remaining trunnion (19).
7. The discharge disc (21) should be fitted onto the discharge drive rod (17).
8. The intermediate housing (3) with the 4 studs (31) can now be located onto the discharge housing (2) and the washers (34) spring washers (35) and nuts (32) tightened to torque values.
9. Place the suction disc (20) over the suction drive rod (18).
10. Carefully mount the suction housing (4) onto the intermediate housing (3) and insert the bolts and washers (34, 35, 37) into their respective places. They should now be tightened to the required torque value.
11. Place the check valve (22) in between the suction housing (4), and swan neck (5). The progressively tighten the bolts (37) to the required torque value.
12. Replace drain plug.

### 9.8 Assembly of the DD100 PS dual disc pump and drive on frame

Position the assembled pump back on its frame and re-fit the mounting nuts and bolts. Place the pulley and belts back into position and refit the Taper Lock Bush as follows :

1. Sparingly oil thread and point of grub screws, or thread and under head of cap screws.
2. Clean shaft and fit hub and bush to shaft as one unit and locate in position desired.
3. Using a hexagon wrench tighten screws gradually and alternatively until all are pulled up very tightly. The bush will grip the shaft first and then the hub will be drawn on to the bush.
4. After drive has been running under load for a short time, stop and check tightness of screws.
5. Fill empty holes with grease to exclude dirt.

⊙ Jacking in screw

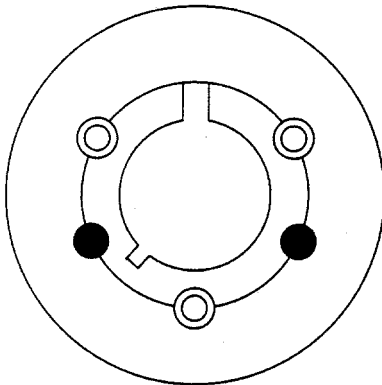

● Jacking off hole

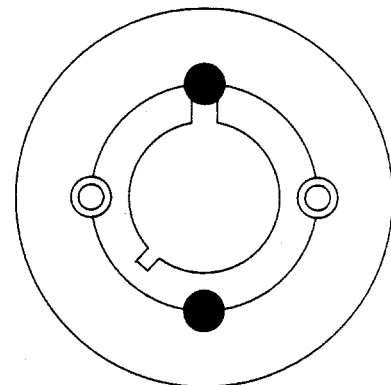

**Operating Manuals**  
**10.0 Faults, causes and remedies**

<b>Symptom</b>	<b>Possible cause</b>	
<b>No prime or slow prime</b>	<ol style="list-style-type: none"> <li>Suction line not air tight</li> <li>Clack valve (if fitted) not seating</li> <li>Strainer clogged</li> <li>Suction lift too high</li> <li>Liquid temperature too high for lift</li> <li>Disc's worn or damaged</li> <li>Disc's not seating properly due to solids accumulation</li> <li>On suction lifts needs liquid head retained in discharge pipework</li> </ol>	<ol style="list-style-type: none"> <li>Cure all air leaks</li> <li>Clean seating and check</li> <li>Clean strainer</li> <li>Lower pump or raise liquid level</li> <li>Cool off liquid before pumping</li> <li>Check and replace disc's</li> <li>Clean out suction housing</li> <li>Ensure pump has liquid in discharge pipework</li> </ol>
<b>Not enough liquid delivered</b>	<ol style="list-style-type: none"> <li>Differential pressure too high</li> <li>Excessive suction lift</li> <li>Pump blocked</li> <li>Pump wear</li> <li>Pump speed too low</li> </ol>	<ol style="list-style-type: none"> <li>Reduce pressure or increase speed to compensate</li> <li>Lower pump or raise liquid level</li> <li>Clean out pump and suction pipe</li> <li>Renovate as necessary</li> <li>Increase pump speed</li> </ol>
<b>Not enough pressure</b> <b>Excessive pressure generated</b>	<ol style="list-style-type: none"> <li>As above</li> <li>Liquid too thick or specific gravity greater than in planned duty</li> <li>Total head too high</li> <li>Closed discharge valve</li> <li>Choked pump or pipeline</li> </ol>	<ol style="list-style-type: none"> <li>As above</li> <li>Reduce distance pumped</li> <li>Reduce total head</li> <li>Open valve</li> <li>Clean out pump and suction pipe</li> </ol>
<b>Excessive vibration</b>	<ol style="list-style-type: none"> <li>Head too high</li> <li>Pump or pipeline blocked</li> <li>Liquid too thick</li> <li>Cavitation due to blocked suction</li> <li>Pump damaged</li> <li>Inadequately supported rigid pipework</li> <li>Excessive pulsation</li> <li>Flow rate over specification</li> </ol>	<ol style="list-style-type: none"> <li>Reduce total head</li> <li>Clean lines</li> <li>Reduce viscosity or use alternative pump</li> <li>Clean out suction line</li> <li>Renovate as necessary</li> <li>Support pipework at closer intervals</li> <li>Fit dampers</li> <li>Reduce pump speed</li> </ol>
<b>Poor drive life</b>	<ol style="list-style-type: none"> <li>Misalignment between drive and pump</li> </ol>	<ol style="list-style-type: none"> <li>Check and rectify alignment</li> </ol>
<b>Poor disc life</b>	<ol style="list-style-type: none"> <li>Head persistently too high</li> <li>Medium attacking disc material</li> <li>Liquid temperature too high</li> </ol>	<ol style="list-style-type: none"> <li>Reduce total delivery head</li> <li>Use optional disc material</li> <li>Reduce product temperature</li> </ol>
<b>Syphoning</b>	<ol style="list-style-type: none"> <li>No forward barrier to flow</li> </ol>	<ol style="list-style-type: none"> <li>Ensure discharge pipework higher than suction tank, syphon break may be required.</li> </ol>

## 11.0 Technical data

---

### 11.1 Pump information chart

The following table details technical data regarding the pump range, for further details contact your supplier. The technical data below must not be used for pump selection purposes.

Pump Model	Maximum Pressure (Bar)	Speed RPM	
		Min	Max
DD50	2 bar (29 psi)	75	720
DD75 PS	3 bar (43.5 psi)	75	350
DD100 PS	3 bar (43.5 psi)	75	750

## Operating Manuals

### 11.2 Torque specification chart

#### DD50 DUAL DISC

Item Number	Description	Torque	
		Nm	lbft
11	Bolt Bearing Retainer	12	9
14	Bearing Grub Screws	10	7
22	Bearing Support Nut	26	19
38	Disc Spacer nut	107	79
42	Disc Retainer Plate Nut	107	79
47	Discharge Pedestal Bolts	45	33
50	Suction Pedestal Bolts	45	33
51	Trunnion Clamp Ring Retention Bolt	45	33
54	Suction Housing Nut	45	33
57	Swan Neck Bolt	45	33
59	Plugs	107	79

#### DD75 PS DUAL DISC

Item Number	Description	Torque	
		Nm	lbft
11	Cam Lobe Grub Screw	26	19
44	Bearing Block Bolts	107	79
47	Bearing Retainer Screw	12	9
28	Disc Retaining Plate Nut	218	161
36	Drive Assembly Retention Nut	72	53
32	Drive Assembly Retention Bolt	72	53
40	Intermediate Housing Nut	107	79
41	Swan Neck/Housing Bolt	107	79

#### DD100 PS DUAL DISC

Item number	Description	Torque	
		Nm	lbft
11	Cam lobe grub screw	20	14
40	Bearing block bolts	56	41
43	Bearing retainer screw	10	7
32	Drive assembly retention nut	72	53
28	Drive assembly retention bolt	72	53
36	Intermediate housing nut	90	65
46	Swan neck / housing bolt	50	35

**The following pages contain**

**Exploded Pump Drawings and Parts Lists**

## Operating Manuals

### 12.0 Exploded Pump Drawing and Parts List

#### 12.1 DD50 Dual Disc Pump

Item	Qty	Description	Part no.
1	2	Pedestal	7-700204
2	1	CI Discharge housing BSP F/M	7-700243
2	1	CI Discharge housing NPT F/M	7-720004
3	1	CI Intermediate housing	7-700242
4	1	CI Suction housing	7-700241
5	1	CI Swan neck BSP F/M	7-700245
5	1	CI Swan neck NPT F/M	7-720001
6	1	Drive shaft 1"	7-700206
7	2	Bearing con rod	7-700230
8	1	Cam lobe 1"	7-700207
9	2	Circlip	7-334911
10	2	Drive pins	7-300878
11	4	Bolt bearing retainer	7-301129
12	12	Spring washer bearing retainer	7-300761
13	4	Washer bearing retainer	7-700232
14	2	Drive shaft bearing 1"	7-700229
15	4	Bearing plates	-----
16	2	Gasket shaft dust cap	7-700263
17	1	Dust cap	7-700261
18	1	Dust cap (Drive End)	7-700262
19	1	Inner seal	7-700264
20	6	Bearing support bolt	7-301128
21	15	Bearing support washer	7-300718
22	12	Bearing support spacer nut	7-300585
23	9	Bearing support spring washer	7-300786
24	2	Con rods	7-700208
25	1	Drive rod short discharge	7-700209
26	1	Drive rod long suction	7-700210
27	1	Drive rod sleeve	7-700211
28	1	Trunnion holder long top (Discharge)	7-700216
29	1	Trunnion holder short bottom (Discharge)	7-700217
30	2	Trunnion clamp ring	7-700214
31	1	Trunnion holder short top (Suction)	7-700215
32	1	Trunnion holder long bottom (Suction)	7-700218
33	2	Trunnion (Nitrile)	7-700213

## Operating Manuals

Item	Qty	Description	Part no.
		Items 34, 35 not shown	
36	2	'O' rings Nitrile	7-334553
37	2	Disc retaining plate (Top)	7-700221
38	2	Disc spacer	7-700223
39	1	Discharge disc (Nitrile)	7-700220
40	1	Suction disc (Nitrile)	7-700219
41	2	Disc retainer plate bottom	7-700222
42	1	Disc retainer plate nut	7-700002
43	1	Check valve (Nitrile)	7-700224
44	3	Check valve spacer (Mild Steel)	7-700225
45	1	Discharge gasket (Nitrile)	7-700228
46	1	Suction gasket(Nitrile)	7-700227
47	2	Discharge pedestal bolts	7-301121
48	27	Washers	7-300783
49	18	Spring washers	7-300784
50	2	Suction pedestal bolts	7-301124
51	1	Trunnion clamp ring retention bolt	7-301120
52	1	Trunnion clamp ring special washer	7-700234
53	4	Housing bolts discharge	7-301125
54	10	Nuts	7-300584
55	2	Housing bolts intermediate	7-301126
56	4	Housing bolts	7-301123
57	3	Swan /neck bolts	7-301122
58	2	Plug washers	31499.5916.1
59	2	Plugs	1660.008
60	2	Pin con rods	7-300877

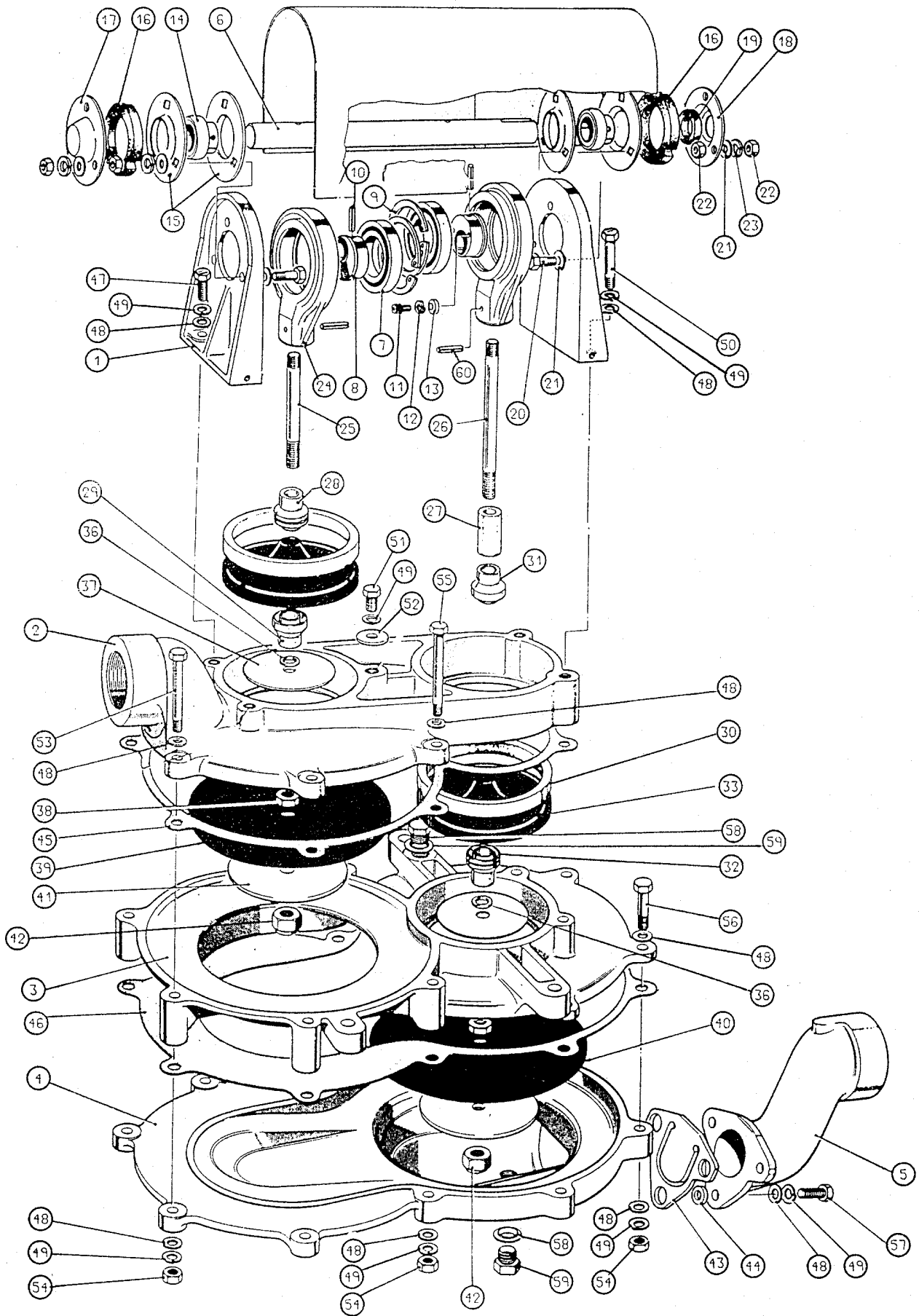

## 12.2 DD75 PS Dual Disc Pump

Item	Qty	Description	Part no.
1	1	Drive support frame	7-731005
2	1	CI Discharge housing NP16	7-730003
2	1	CI Discharge housing BST D	7-730103
2	1	CI Discharge housing ANSI-150	7-730203
3	1	CI/ Intermediate housing	7-730002
4	1	CI/ Suction housing	7-730001
5	1	CI/ Swan neck BST D	7-730104
5	1	CI/ Swan neck NP16	7-730004
5	1	CI/ Swan neck ANSI-150	7-730204
6	1	Drive shaft	7-741005
7	2	Bearing con rod	7-730013
8	2	Cam lobe	7-730010
9	4	Circlip	7-730017
10	3	Key	7-730016
11	4	Grubscrew	7-301151
12	3	Bearing block	7-730014
13	1	Con rod discharge	7-730009
14	1	Con rod suction	7-730008
15	1	Clamp ring discharge	7-700316
16	1	Clamp ring suction	7-700315
17	1	Drive rod discharge	7-700313
18	1	Drive rod suction	7-700312
19	1	Spirol pin	7-335017
20	2	Trunnion (Nitrile reinforced)	7-730020
21	1	Clamp collar discharge	7-700661
22	1	Clamp collar suction	7-700659
23	2	Disc retainer plate top	7-700319
24	2	Disc spacer nut (not required on lined pump)	7-700320
25	1	Discharge diaphragm (Nitrile)	7-700350
26	1	Suction disc (Nitrile)	7-700351
27	2	Disc retainer plate bottom	7-700322

## Operating Manuals

Item	Qty	Description	Part no.
28	2	Disc retainer plate nut	7-700006
29	1	Check valve (Nitrile)	7-730097
30	1	Discharge gasket (EPDM)	7-730025
31	1	Suction gasket (EPDM)	7-730024
32	4	Drive assembly retention bolt	7-301133
33	8	Drive assembly retention washer	7-300790
34	8	Drive assembly retention spring washer	7-300789
35	4	Drive assembly retention spring stud	7-700335
36	4	Drive assembly retention spring nut	7-300589
37	8	Housing bolt	7-301132
38	26	Housing washer	7-300787
39	20	Housing spring washer	7-300788
40	8	Housing spring nut	7-300588
41	12	Swan neck and housing bolt	7-301131
42	4	Plug	1660-008
43	1	Pump cover	7-730015
44	6	Screw	7-301146
45	7	Screw	7-301130
46	13	Washer	7-300719
47	6	Screw	7-301135
48	6	Washer	7-300761
49	6	Bush clamp	7-730012

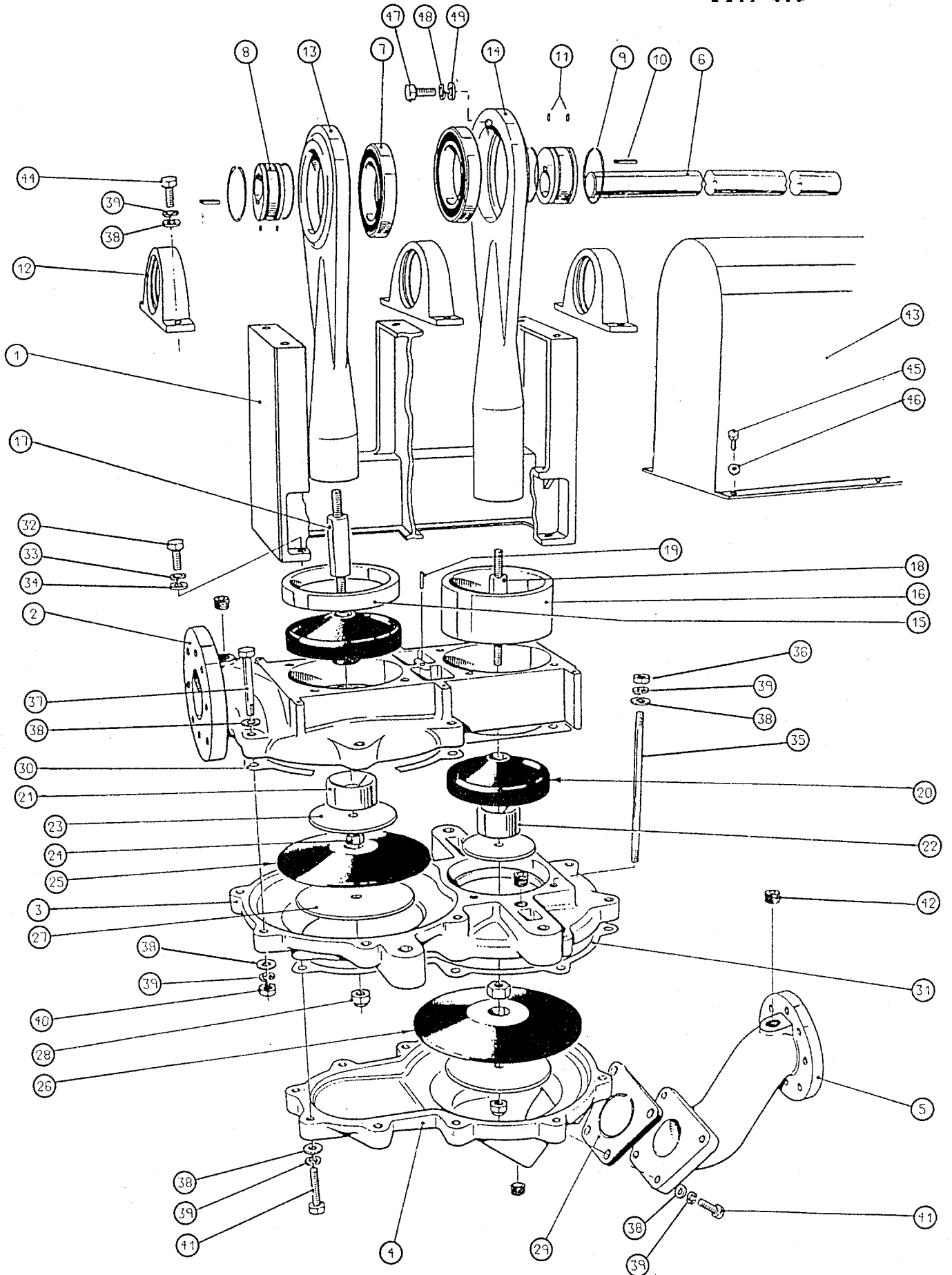

## Operating Manuals

### 12.3 DD100 PS Dual Disc Pump

Item	Qty	Description	Part no
1	1	Drive support frame	7.731005
2	1	CI discharge housing NP 16	7.740093
2	1	CI discharge housing BS 10 D	7.740193
2	1	CI discharge housing ANS I - 150	7.740293
3	1	CI intermediate housing	7.730002
4	1	CI suction housing	7.740001
5	1	CI swan neck NP 16	7.740004
5	1	CI swan neck BS 10 D	7.740104
5	1	CI swan neck ANS I - 150	7.740204
6	1	Drive shaft	7.741005
7	2	Bearing con rod	7.730013
8	2	Cam lobe (St. Stl.)	7.730010
9	4	Circlip	7.730017
10	3	Key	7.730016
11	4	Socket set screw	7.301151
12	3	Bearing block	7.730014
13	1	Con rod discharge	7.730009
14	1	Con rod suction	7.730008
15	1	Clamp ring discharge	7.700316
16	1	Clamp ring suction	7.700315
17	2	Drive rod	7.740312
18	1	Spirol pin	7.335017
19	2	Trunnion (Neoprene)	7.730021
20	1	Suction (lift) disc (Neoprene)	7.740351
21	1	Discharge (flow) disc (Neoprene)	7.740350
22	1	Check valve (Neoprene)	7.740326
26	1	Discharge gasket	7.730025
27	1	Suction gasket	7.730024

## Operating Manuals

Item	Qty	Description	Item no
28	4	Drive assembly retention bolt	7.301133
29	4	Drive assembly retention washer	7.300790
30	8	Drive assembly retention spring washer	7.300789
31	4	Drive assembly retention spring stud	7.700335
32	4	Drive assembly retention spring nut	7.300589
33	8	Housing bolt	7.301132
34	28	Housing washer	7.300787
35	20	Housing spring washer	7.300788
36	8	Housing spring nut	7.300588
37	8	Housing bolt	7.301131
38	4	Plug	1660.008
39	1	Pump cover	7.730015
40	6	Screw	7.301146
41	7	Screw	7.301130
42	13	Washer	7.300719
43	6	Screw	7.301135
44	6	Washer	7.300761
45	6	Bush camp	7.730012
46	4	Swan neck bolt	5950.081

