

User Benefits

- High efficiency
- Low energy consumption
- Robust construction
- Smooth flow
- Reversible operation
- Ability to pump abrasive media
- Ability to pump large solids
- Cost effective easy maintenance

Series A & G

Rotary Lobe Pumps for customised engineered solutions

SSP Series A and Series G rotary lobe pumps are designed for high volume fluid transfer duties and are amongst the world's largest pumps of this type. Both series are engineered to order, customised to suit application requirements throughout Chemical, Food, Pharmaceutical and Waste Water Treatment processes.

From initial enquiry, the specification of the pump will be engineered to ensure the most appropriate pump is provided to meet application requirements.

Series A pumps, manufactured from stainless steel, can handle from low to high viscosity pumped media. Ideal for delicate media and where organic solids in suspension, creams, froths, gels, emulsions and mixtures are to be pumped.

Series G pumps, manufactured from ductile iron, operate within general industrial and waste water treatment processes providing a good

tolerance of suspended solids including fibrous matter. Series G pumps have proven ability in handling a full range of sludge thickness with rag and grit included.

Operation

The positive displacement of both Series A and Series G pumps is provided by non-contacting, contra rotating tri-lobe rotors within a fully swept pump chamber. All Series A and Series G pumps are capable of bi-rotational flow without modification.

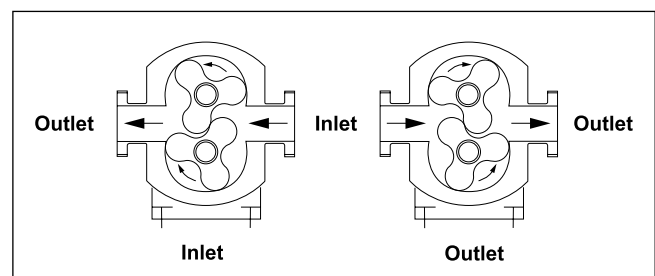

Performance

Both Series A and Series G pump ranges have five pump head displacements ranging from 550 litres/100rev to 2270 litres/100rev.

- Flow rates up to 680 m³/h
- Differential pressures up to 10 bar
- Port sizes from 150 mm to 300 mm diameter

High Volumetric Efficiency - Both Series A and Series G pumps offer high efficiency transfer of low, medium and high viscosity pumped media. This important aspect of performance is achieved by maintaining high accuracy and repeatability of component part manufacture, thereby maximising shaft rigidity and minimising the effects of thermal expansion within the pump gearbox. This combination allows the optimum pump head geometry to be achieved which, in turn, maximises volumetric efficiency.

Basic Design

Pumphead – All metallic pumped media wetted components are manufactured in 316 type stainless steel for Series A and ductile iron for Series G. The Series A in standard specification has stainless steel tri-lobe rotors available in three temperature ratings, allowing the pump to be operated at maximum temperatures of 70°C, 130°C and 200°C for both process and CIP. The Series G in standard specification has tri-lobe rotors manufactured from ductile iron (for non-sludge applications) or a metal insert covered with either NBR (which can be fitted with metal back plates for high fibre duties) or urethane, both giving long term wear resistance.

- Shafts** - Series A pumps, manufactured from 316 type stainless steel.
- Series G pumps, manufactured from medium carbon steel.

Gearbox – Both Series A and Series G pumps have a robust cast iron gearbox, which provides maximum shaft rigidity. Heavy duty taper roller bearing arrangements provide maximum support for both drive and auxiliary shafts.

Pump Model	Inlet and Outlet Connection Size (International Standards) mm	Displacement litres/100rev	Differential Pressure bar	Maximum Speed rev/min	Weight Bare Shaft Pump kg
A7-0550-H07	150	550.0	7*	750	307
A8-0745-H10	150	745.0	10	650	590
A8-1149-H03	200	1148.6	3.5*	650	700
A9-1507-H10	250	1507.3	10	500	1362
A9-2270-H10	300	2270.0	10	500	1410
G7-0550-H07	150	550.0	7*	750	307
G8-0745-H10	150	745.0	10	650	590
G8-1149-H03	200	1148.6	3.5*	650	700
G9-1507-H10	250	1507.3	10	500	1362
G9-2270-H10	300	2270.0	10	500	1410

* Higher pressures attainable - please refer to SSP Pumps

Specification Options

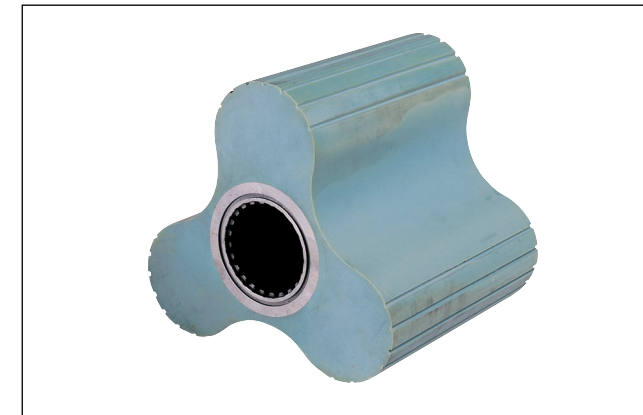

Wear plates

Series G pump casings may be supplied fitted with hardened, replaceable wear plates (standard on sludge pumps). The wear plates can be replaced in situ with minimal pump dismantling.

Pumped media seals

The optimum primary seal can be chosen to match the pumped media and duty conditions. Single or double mechanical seals include flushed or aseptic variants. For arduous duties hard faced seal materials such as tungsten carbide or silicon carbide can be used. Cartridge mechanical seals are available for sludge and other difficult applications.

Packed glands offer a simple, low cost, and easy to maintain controlled leakage sealing arrangement.

Pumped media wetted elastomers are EPDM, NBR, FPM all FDA conforming or PTFE for chemical applications.

Connections

Pump casings are supplied with integral cast flanged inlet and outlet connections to all major standards including ASA/ANSI150, BS4504/DIN2533, BS10E and more.

Rotor materials

For increased abrasion resistance pumps may be supplied with NBR covered (models A7-0550-H07, A8-0745-H10, G7-0550-H07 and G8-0745-H10 only) or urethane rotors (Series G only). The urethane rotors can be supplied slotted, providing grit channels to improve rotor life.

Surface finish and coatings

For abrasive applications the pumphead and rotors may be supplied with a tungsten carbide coating or other surface hardening treatment to increase wear resistance.

Increased pressure rating

Alternative higher strength shaft materials will enhance pressure ratings.

- 10 bar for pump models A7-0550-H07 and G7-0550-H07
- 7 bar for pump models A8-1149-H03 and G8-1149-H03

Motorised pump units

Pumps may be supplied fully motorised with fixed or variable speed drives including appropriate control systems if required, mounted on either mild steel or stainless steel baseplates. In addition to electric motor drives, hydraulic, pneumatic, diesel or petrol powered prime movers can be fitted.

Series A & G

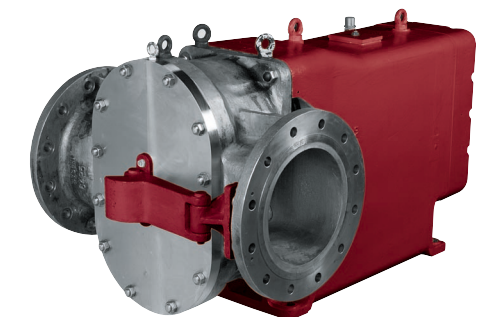

Bareshaft Pump Dimensions

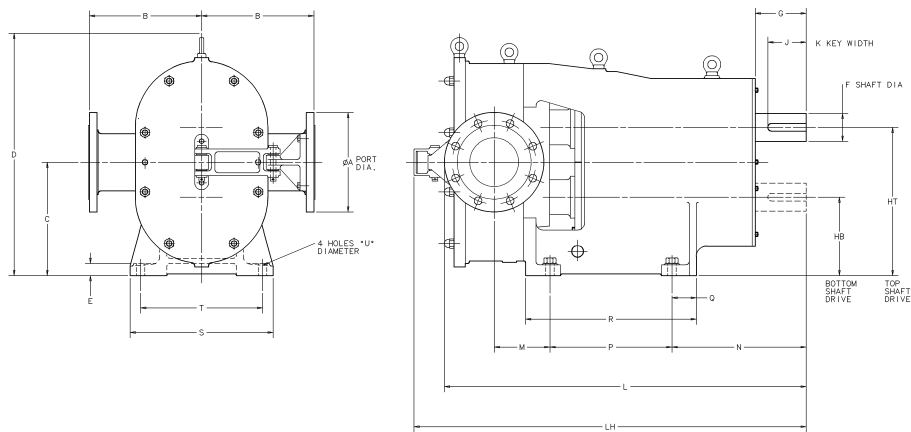

All dimensions in mm

Pump Model	A	B	C	D	E	F	G	HB	HT	J	K	L	LH	M	N	P	Q	R	S	T	U
A7-0550-H07	150	225	276	588	22	55	110	190	362.5	90	16	850	915	127	225	350	20	390	224	180	17
A8-0745-H10	150	325	325	682	35	80	146	225	425	110	22	1038	1125	160	385	350	70	490	410	350	24
A8-1149-H03	200	325	325	682	35	80	146	225	425	110	22	1107	1202	200	385	350	70	490	410	350	24
A9-1507-H10	250	400	450	850	35	120	165	325	575	140	32	1536	1578	196	367	750	35	820	350	280	28
A9-2270-H10	300	400	450	850	35	120	165	325	575	140	32	1608	1663	246	367	750	35	820	350	280	28
G7-0550-H07	150	225	276	588	22	55	110	190	362.5	90	16	850	915	127	225	350	20	390	224	180	17
G8-0745-H10	150	325	325	682	35	80	146	225	425	110	22	1038	1125	160	385	350	70	490	410	350	24
G8-1149-H03	200	325	325	682	35	80	146	225	425	110	22	1107	1202	200	385	350	70	490	410	350	24
G9-1507-H10	250	400	450	850	35	120	165	325	575	140	32	1536	1578	196	367	750	35	820	350	280	28
G9-2270-H10	300	400	450	850	35	120	165	325	575	140	32	1608	1663	246	367	750	35	820	350	280	28

Sales - Pumps: +44 (0)1323 414600
Spares: +44 (0)1323 414601



The information contained herein is correct at the time of issue,
but may be subject to change without prior notice